

# **MDR-304**

## Digital Video Recorder

### Instruction Manual



# SAFETY PRECAUTIONS









All the following safety and operation instructions which will prevent harm or damage to the operator or other persons should be read before the unit is operated.

## INFORMATION



This equipment has been tested and found to comply with the limits for a Class A digital device, pursuant to Part 15 of the FCC Rules. These limits are designed to provide reasonable protection against harmful interference when the equipment is operated in a commercial environment. This equipment generates, uses, and can radiate radio frequency energy and, if not installed and used in accordance with the instruction manual, may cause harmful interference to radio communications.

Operation of this equipment in a residential area is likely to cause harmful interference in which case the user will be required to correct the interference at his own expense.

## WARNING

-  To reduce the risk of fire or electric shock, do not expose this appliance to rain or moisture.
-  Do not block ventilation openings.
-  Do not place anything on top of the unit that might spill or fall into it.
-  Do not attempt to service this unit yourself as opening or removing covers may expose you to dangerous voltage or other hazards. Please refer all servicing to qualified service personnel.
-  Do not use liquid cleaners or aerosols for cleaning.
-  This installation should be made by a qualified service person and should conform to all local codes.
-  To prevent fire or electric shock, do not overload wall outlets or extension cords.
-  This unit must be grounded to reduce the risk of electric shock hazard.

## CAUTION

-  Danger of explosion if battery( RTC Battery ) is incorrectly replaced. Replace only with the same or equivalent type recommended by the manufacturer. Dispose of used batteries according to the manufacturer's instructions.
-  Risk of explosion if replaced by an incorrect type. Dispose of used batteries according to the instructions.

# CONTENTS

1.2 Product Introduction .....	3	3.3.3 Slow Forward/Reverse .....	21
1.3 Product Features .....	4	3.3.4 Play back picture-by-picture.....	22
1.5 THE FRONT / REAR VIEWS .....	5	3.4 The Search Operations .....	22
1.5.1 The Front View .....	5	3.4.1 The FULL LIST Search .....	22
1.5.2 The Rear View .....	7	3.4.2 The ALARM LIST Search .....	22
1.5.3 The Inner Caddy Rear View.....	8	3.4.3 The TIME Search .....	23
1.5.4 The GPS Connector.....	8	3.4.4 The THUMBNAIL Search .....	23
1.5.5 The Camera In Connector .....	9	3.4.5 The SD CARD Search .....	24
1.5.6 The Power Delay Connection .....	9	3.5 The Backup Operations .....	25
1.5.7 The Power Connector .....	10	3.5.1 The SD Card Backup Operations.....	25
1.6 I/O Port.....	11	3.6 The Key Lock Operation .....	26
.....	11	<b>4. MENU SETUP .....</b>	<b>27</b>
1.7 The I/O Connections .....	12	4.1 The REC Setting .....	27
1.8 Voltage Management .....	13	4.2 The ALARM Setting .....	29
<b>2. INSTALLATION .....</b>	<b>14</b>	4.3 The CLOCK/ TITLE Setting.....	31
2.1 The Basic Connections .....	14	4.4 The COMMUNICATION Setting.....	32
2.3 System Information and .....	16	4.5 The DISK Setting .....	32
Channel Selection.....	16	4.6 The SYSTEM Setting .....	33
2.3.1 System information .....	16	4.7 Notices of Motion and Alarm Setting....	35
2.3.2 Channel Selection.....	16	5.1 The RS-232 Setup & Protocol.....	36
2.4 Updating the System Software .....	17	5.1.1 The RS-232 Protocol.....	36
<b>PERATIONS .....</b>	<b>18</b>	5.1.2 The Communication Protocol.....	36
3.1 Configuring the Recording Settings .....	18	5.2 The System Default.....	39
3.2 The Recording Operations .....	20	5.3 O.S.D Messages .....	40
3.2.1 Manual Recording.....	20	5.4 The Time Index Table .....	41
3.2.2 Alarm Recording .....	20	5.5 Specifications .....	42
3.2.3 Externally Triggered Recording .....	20	APPENDIX 1. –FAQ.....	43
3.3 The Playback Operations.....	21	APPENDIX 2: Quick Installation Guide .....	44
3.3.1 Normal Playback.....	21		
3.3.2 Fast Forward/Backward .....	21		

# INTRODUCTION (continued)

## 1.2 Product Introduction

This MDR-304 is an advanced vehicle video recorder. It can simultaneously display real-time images from four cameras along with information data via the mobile video recorder screened directly onto your monitor. The mobile MDR-304 has four video channels which you can access either in the quad mode or in single channel.

We use a hard disk device in this mobile recorder to store your images over a longer time. The recording device has already been further tested for shock-proof and extreme temperature-proof durability in rugged environments, with ventilation holes provided to lower the internal temperature for cooling.

The special design of our MDR-304 enables you to easily retrieve the recording caddys inside, which are handy and portable enough to carry anywhere you want and link up with PCs and TV monitors for direct display.

The MDR-304 includes the Global Position System (GPS) which helps disclose a vehicle's location information -- the GPS information can also be displayed by eMap software to learn about a car's exact route. The MDR-304 can also be connected to the car's information Black Box to access a vehicle's driving speed, engine RPM, wheel turns, driving time periods, braking, signal lights, and so on, all of which data is received and saved by the MDR-304. While searching for information, any important image you may want to save can be stored via an SD card.

This mobile recorder provides all the above practical and useful features you can expect of it. It's your best possible choice out of the entire range of mobile video recorders available. This multi-functional mobile video surveillance product protects the safety of both the driver and the passengers.

## 1.3 Product Features

- Quad-based operation: real-time operation and playback (30 FPS/ per channel).
- M-JPEG compression with resolution up to 720X480 (NTSC) / 720X576 (PAL).
- 4x 6-pin Din connectors for AV inputs.
- 4 camera audio inputs, 2 auxiliary audio inputs, 1 audio output.
- The HDD's video records can be plugged in and played back on a TV directly.
- Pre-alarm image recording.
- USB interface showing video records in a PC.
- 1 fixed 2.5" IDE HDD as storage medium for extended continuous digital recording.
- Supports GPS (RS-232).
- GPIO: 4 inputs and 2 outputs.
- Operating Voltage: 12Vdc.
- Maximum Current: 1.2 Amps.
- Power Consumption: 15 Watts.
- Operation temperature: Standard HDD: 0 – 45°C (32 –113°F)  
Industrial HDD: 0 – 60°C (32 –140°F)
- Dimensions: 178 x 173 x 50 mm.
- Time-lapse and real-time recording.
- Refresh rates up to 30 IPS (25 IPS for PAL).
- Image quality selectable at 4 different levels for recording.
- Alarm recording mode.
- Quick search by time, alarm, event, and recording list.
- Fast and slow playback of recorded video at various speeds.
- Single-picture playback.
- On-screen setup menu, title and system timer.
- Password protection.
- Disk-full warning and operation status LEDs.
- RS-232 communication port.
- Remote controller.
- Operation-status record log.
- Automatic detection of the current voltage.
- Audio function included.
- Built-in SD card slot for copying images to an SD card.
- Watermark.
- Window Division.
- Vibration and mechanical shock protection.

## 1.5 THE FRONT / REAR VIEWS

### 1.5.1 The Front View

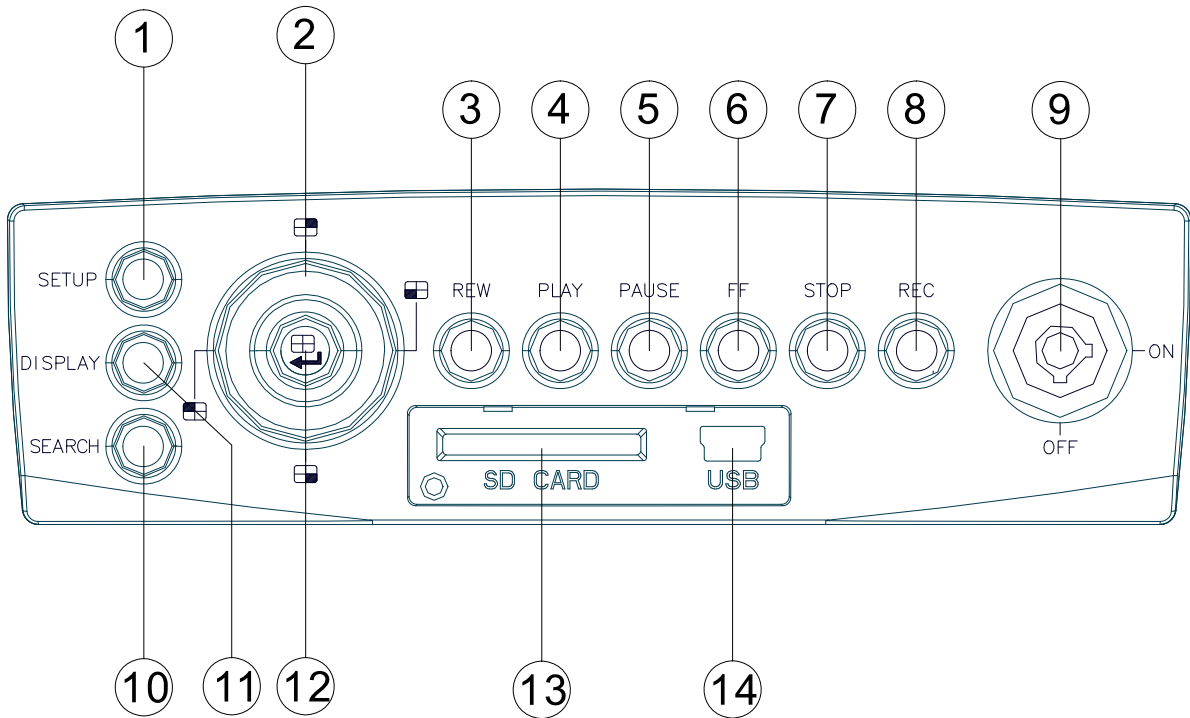

- ① **SETUP** button:  
Press this to enter the setup menu. Press again to exit the setup mode.
- ② **Left/ Right/ Up/ Down (CH1/ CH2/ CH4/ CH3)** buttons:  
In the menu setup mode / search mode, press the four buttons on the dial to highlight desired items in the menu setup mode. In the live / play mode, press the four buttons on the dial to select a channel for display.
- ③ **REW** button:  
Press this to play a recorded video in the reverse direction at a speed that's faster or slower than the recorded speed in the play mode.
- ④ **PLAY** button:  
Press to play back a recorded video from the hard disk. (A light glows green in the PLAY mode.)
- ⑤ **PAUSE** button:  
In a playback display, press this to freeze the display. During the freeze, press to display one frame of a picture at a time in the forward direction ( a light glows red in the PAUSE mode.)
- ⑥ **FF** button:  
Press this to play a recorded video in the forward direction at a speed that's faster or slower than the recorded speed in the play mode
- ⑦ **STOP** button:  
Press to stop playing back a recorded video ( a light glows red in the STOP mode.)
- ⑧ **REC** button:  
Push to start recording video into a hard disk while in the live display mode.( a light glows red in the REC mode.)

- ⑨ **Inner-case lock:**  
This key lock secures the inner case with the hard disk in place. When you lock it in, it powers on the device. When you unlock this key and take out the inner case, the power turns off automatically.
- ⑩ **SEARCH** button:  
Press to enter the search mode to access recorded video.
- ⑪ **DISPLAY** button:  
Press to show the system operation status on the screen.
- ⑫ **Enter** /  (**Quad**) button:  
Press to enter a selected item and save the setting in the menu setup mode. In the live/ play mode, use this button to show a quad display.
- ⑬ **SD CARD** slot:  
This is used for system software updating and archiving/ accessing of critical images.
- ⑭ **USB** port:  
This is used for system picture playing. Use this port to connect with your PC or notebook. You can easily and quickly capture data from a hard disk in the vehicle MDR-304.

## 1.5.2 The Rear View

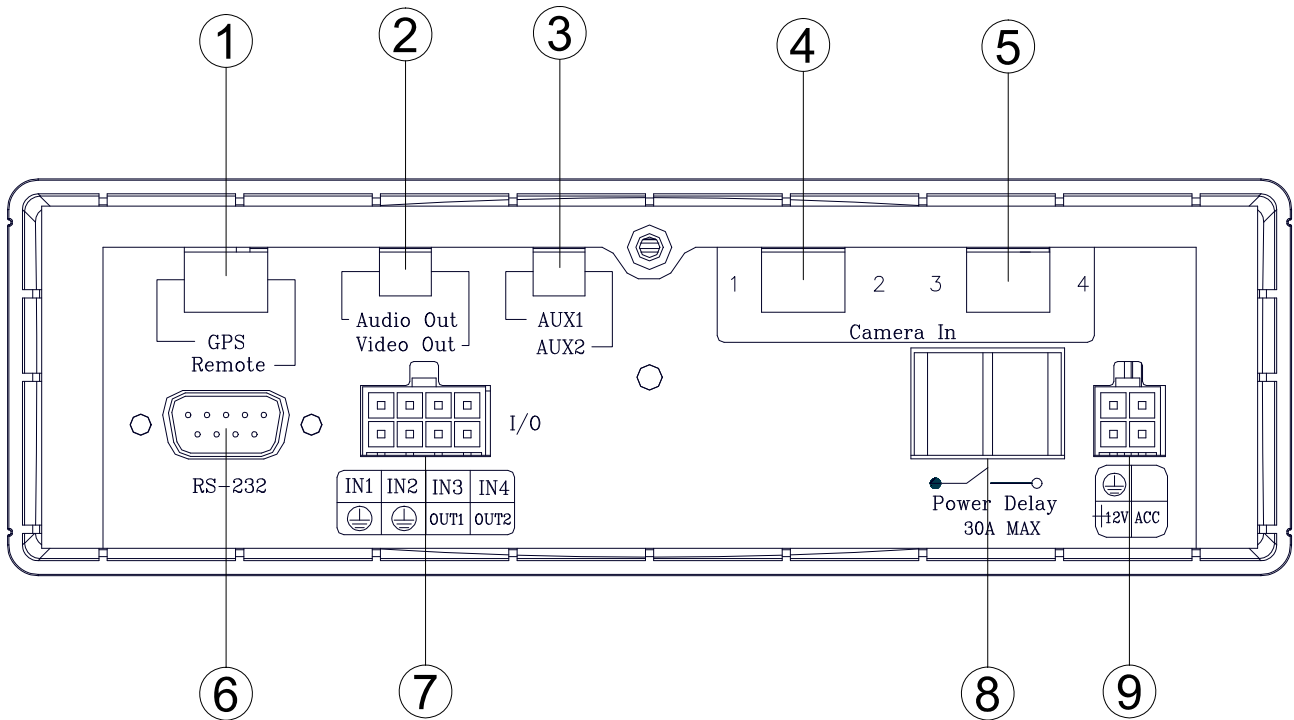

- ① **GPS & Remote Controller Connector:**  
The left side connector links up with the GPS receiver to capture local position information data. Please refer to section **1.5.4 GPS CONNECTOR**. The right side connector links up with the remote controller
- ② **Audio Out / Video Out:**  
Your LCD monitor or other monitor can signal here.
- ③ **AUX 1 / AUX 2:**  
Use this if you have external audio sources.
- ④⑤ **Camera In connector:**  
There are four connectors here to connect the Video / Audio In from a camera. Please refer to section **1.5.5 CAMERA IN CONNECTOR**.
- ⑥ **RS 232 port:**  
This communication port functions as a connector to an external device, for example a data box.
- ⑦ **I / O port:**  
This connector links up with an external device.
- ⑧ **Power Delay:**  
This connector will avoid the vehicle device getting excess power. Please refer to section **1.5.6 POWER DELAY CONNECTION**.
- ⑨ **Power Input:**  
This connector links up with the power from the vehicle (12V). Please refer to section **1.5.7 POWER CONNECTOR**.



### 1.5.3 The Inner Caddy Rear View

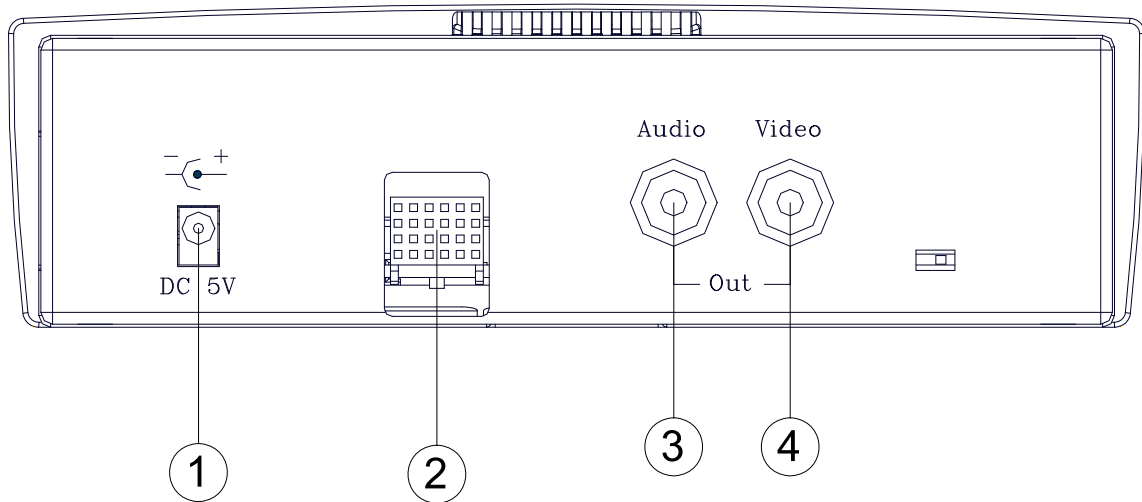

- ① **Plug Inlet:**  
The inlet connects to an external power supply. Connect to the 5V DC UL Listed Class 2 Power Supply.
- ② **Hard Metric Connector (Male):**  
This connector links up with the outer casing.
- ③ **Audio Connector:**  
Connect here to hear the audio's sound when you play the inner caddy case outside the outer case.
- ④ **Video Connector:**  
Connect here to play the video when you play the inner caddy case outside the outer case.

### 1.5.4 The GPS Connector

( The PS/2 composition of the male connector )

PIN NO.	PIN assignment
1.	+ 5V DC
2.	Not Connected
3.	RX
4.	Ground
5.	TX
6.	Not Connected

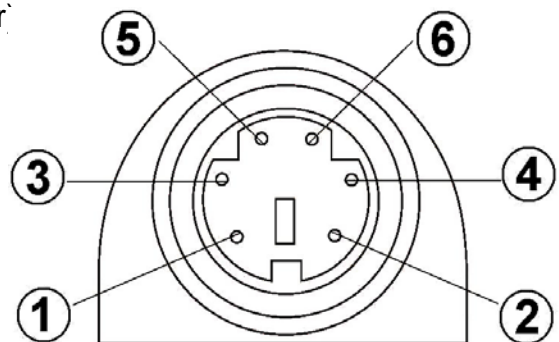

### 1.5.5 The Camera In Connector

( PS/2 composition of the female connector)

PIN NO.	PIN assignment
1.	Audio In
2.	Not Connected (Mirror)
3.	+ 12V DC
4.	Video In
5.	Ground
6.	Ground

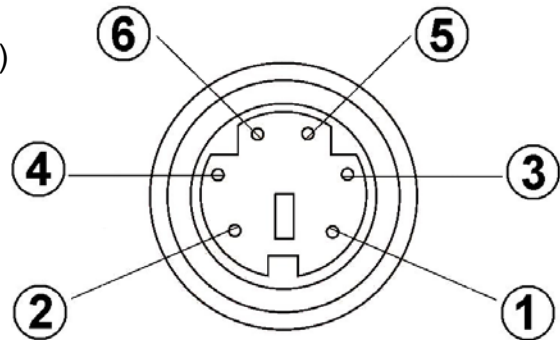

**Note:** The maximum electric current provided for 4 mobile cameras is 1 ampere ( 1A ) in total.

### 1.5.6 The Power Delay Connection

The diagram here illustrates the power delay connection structure. If a device needs to work with our MDR-304, it needs to start operating **after** our MDR-304 has begun operating. See the diagram below to help you with the mobile vehicle video recorder's power delay connector on its rear panel.

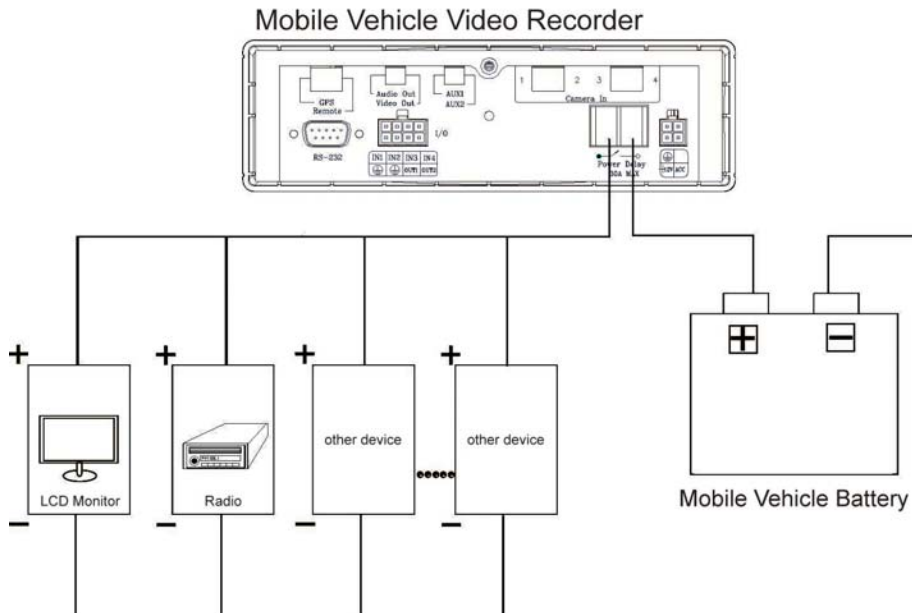

Enter the mobile vehicle MDR-304's **"MAIN MENU"** page and choose the third item, **"CLOCK / TITLE"**. Now enter the **"CLOCK / TITLE"** page, and you will see two items, **"DELAY ON"** and **"DELAY OFF"**. For both these items, the default setting is **"OFF"**. You can set the delay time of the relay by choosing one of the following options.

**DELAY ON:** This entry sets the delay time of the function activation of the relay connector after the MDR-304 powers up.

**DELAY OFF:** This entry sets the delay time of the function activation of the relay connector after the ACC is powered off. The relay connector will function as per the delay time you set by your chosen option. After the relay connector's delay time duration is over, the relay connector will automatically turn off, followed by the MDR-304 ( the MDR-304 which is connected with the cigar-lighter of a vehicle for power supply will stop working when the ignition is turned off).

**Note:** The relay connector's electric current range goes to a maximum of 30 amperes.

**Note:** Our **"POST REC DURATION"** function also sets the time as per any of the six options available, after the ACC has been turned off. Please always be mindful of the fact that, if the time duration set for either **"DELAY OFF"** or **"POST REC DURATION"** is longer than the other one, the MDR-304 will wait for the longer setting to end before shutting down.

## 1.5.7 The Power Connector

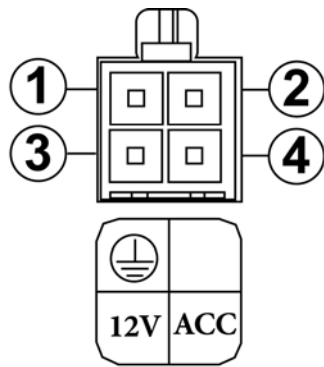

- ① **GND:** Ground contact.
- ② **Not used.**
- ③ **12 V:** This pin is connected to the vehicle battery.
- ④ **ACC:** This pin is linked to the vehicle ignition key to start the MDR-304.

### Pin connections with the ignition key

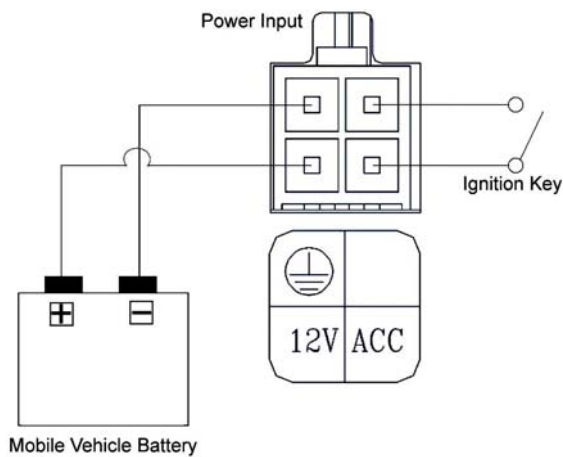

In the above diagram, pin 1 is connected to the vehicle battery minus, pin 3 to the battery plus, and pin 4 to the vehicle ignition key. We suggest the connection of the diagram above.

**Note:** In the “Pin connections with the ignition key” connection mode, the MDR-304 supports the “DELEY OFF” and the “POST-REC DURATION” functions.

Please refer to sections “4.1” and “4.7” for using the post-record settings.

**Note:** If the mobile vehicle battery is over 16.1 volts or under 10.4 volts, the MDR-304 will not work.

**Warning:** In the “Pin connections without the ignition key” connection mode of the right-side diagrams, the MDR-304 can’t support the “DELEY OFF” and the “POST-REC DURATION” functions.

### Pin connections without the ignition key

#### Connect with the Battery

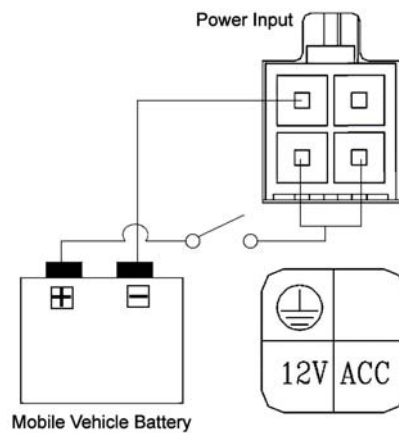

In the above diagram, pin 1 is connected to the vehicle battery minus, and pins 3 and 4 are connected together to the vehicle battery plus.

## 1.6 I/O Port

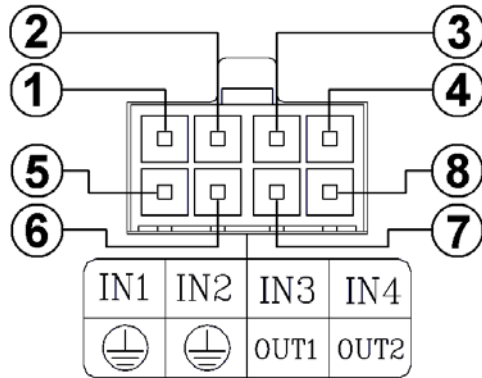

This figure is seen from the rear view.

- I/O IN1 (INPUT):** This is an alarm input which can be programmed in the menu system to Normally Open or Normally Closed.

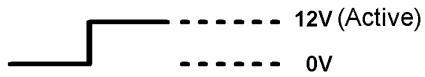

- I/O IN2 (INPUT):** same as above.
- I/O IN3 (INPUT):** same as above.
- I/O IN4 (INPUT):** same as above.
- GND:** Ground Contact.
- GND:** Ground Contact.
- I/O OUT1 (OUTPUT):** This is an alarm output trigger. Connect this to external devices such as buzzers or lights.

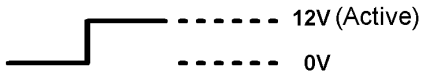

- I/O OUT2 (OUTPUT):** This is an alarm output trigger. Connect this to external devices such as buzzers or lights.

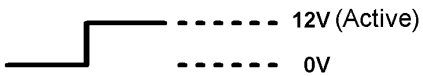

## 1.7 The I/O Connections

### ALARM:

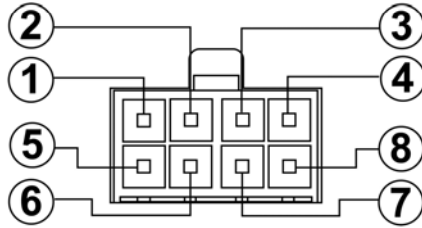

In the "MAIN MENU" page, click "ALARM" to enter the "ALARM" page. In this page, go to the "I/O CONNECTION" item which has two options, "ALARM" and "VEHICLE SIGNAL". If you choose "ALARM", the I/O port will change its meanings:

Pins 1, 2 and 3 will become an alarm input which can connect with three different sensors and receive a trigger; pin 4 can receive the "Reset" trigger; and pins 5 and 6 are ground contacts; pin 7 can send out an alarm output trigger from pins 1, 2 and 3, and connect to external devices like buzzers or lights; and pin 8 is N/A (not applicable).

### VEHICLE SIGNAL:

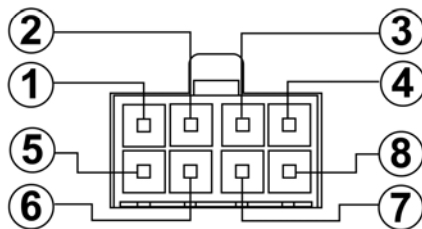

In the "MAIN MENU" page, click "ALARM" to enter the "ALARM" page. In this page, go to the "I/O CONNECTION" which has two options, "ALARM" and "VEHICLE SIGNAL". If you choose "VEHICLE SIGNAL", the I/O port will change its meanings:

Pin 1 will connect with the leftside car signal light and receive the trigger signals; pin 2 will connect with the rightside car signal light and receive the trigger signals; pin 3 is N/A (not applicable); pin 4 can connect with the car stopping signal light to receive the brake triggering signals; pins 5 and 6 are ground contacts; and pins 7 and 8 are N/A (not applicable).

## 1.8 Voltage Management

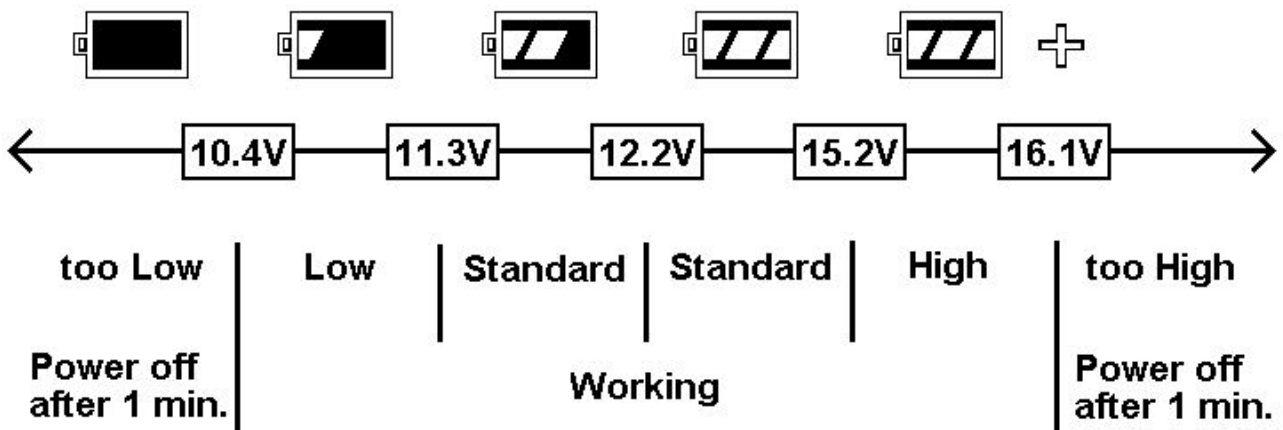

You can display the system - setting information after you press the "DISPLAY" button on the front panel. On this screen you can see the battery voltage icons. Please consult the above diagram to know the battery voltage status.

Between 10.4 volts and 16.1 volts, the battery is in the "Working" mode.

Between 11.3 volts and 15.2 volts, the battery is in the "Standard" mode.

Between 10.4 volts and 11.3 volts, the battery is in the "Low" mode.

Between 15.2 volts and 16.1 volts, the battery is in the "High" mode.

If the voltage is less than 10.4 volts, the battery is in the "Too low" mode", hence the MDR-304 will automatically power off after 1 minute of beeping, and there will be a problem in starting a small-scale car.

If the voltage is more than 16.1 volts, the battery is in the "Too high" mode, and the MDR-304 will automatically power off after 1 minute of beeping.

Note: 1. After the car motor is switched on ( ACC-On ) for 3 minutes, even if the voltage is too high or too low, the MDR-304 won't shut down, only beep.

2. When the car motor is switched off ( ACC-Off ), the MDR-304 will power off, too, after 1 minute of beeping.

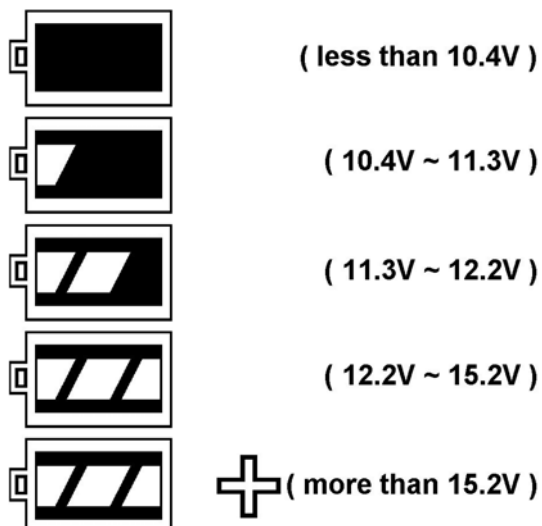

# 2. INSTALLATION

## 2.1 The Basic Connections

### The Mobile Video Surveillance Solution

This is the mobile MDR-304, our video surveillance device for durable use in a vehicle. It's a multipurpose, multi-source, multi-media device for monitoring your vehicle, pinpointing its route and location, and recording and playing vital incidents related to it, in the interests of vehicle security and welfare.

The mobile MDR-304 provides advanced text insertion technology that is compatible with mobile black boxes which record all the relevant details of driving. For example, all information regarding the driving speed, engine RPM, wheel turning angles, driving time periods, brakings, signal lights, and the GPS position can be retrieved from the black box system. The data can be stored, recorded and transferred to a computer or to the mobile MDR-304 directly for data storage and retrieval to ensure a car fleet's and/ or individual driver's quality performance.

The mobile MDR-304 is compatible with the stand-alone GPS receiver, and it can also configure and record a driver's location (latitude and longitude) with video data. Besides, it can playback video by our HDD viewer software, which can track a driven route using all GIS/e-Map software.



The MDR-304 is also linked by Din connectors to four cameras recording all events and scenes around the vehicle, and also to two auxiliary audio recorders for stereo recording of sounds of the vehicle and its surroundings. These provide a complete record of all critical incidents relating to your vehicle.

Inside the outer case of the MDR-304 is the inner, recording caddy. You can take out this light, portable caddy whenever you like and take it with you wherever you want. To play its recorded contents you can connect it to a PC and use the hard disk drive viewer software to play back the video information. In addition you can use a USB interface to connect the MDR-304 to the PC and use eMap software to map the exact route your vehicle has taken. The inner caddy can also be linked by video and audio outputs to a monitor to play back its records. Finally, you can insert an SD card into the SD card slot in the caddy's front panel to record video clips of the most vital images and sections of the recordings you want.



# INSTALLATION ( continued )

## 2.3 System Information and Channel Selection

### 2.3.1 System information

You can display system settings information as shown on **Table 3.3 A** below at any time by pressing the **Display** button. In the playback mode, the recorded video information is displayed. In the live or recording mode, the Manual Recording information is displayed. Each sequential press of the **Display** button displays a different message detailed in the following example. By default, the unit displays the time and date as well as an indicating bar for the capacity status of a monitor as shown here.

#### Default Display

CH1	CH2
CH3	CH4 01/01/2006 12:00:00

**CH1, CH2, CH3, CH4** are titles for each channel, changeable in the Setup menu.

#### Capacity Status :

( Capacity Used ) ( Capacity Remaining )

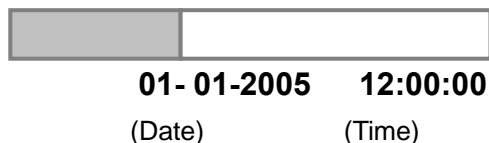

Press the **Display** button once, and the MDR-304 will display the following sample message plus the default display. Press the **Display** button again, and the unit will not

display any OSD message. Press the button one more time to go back to the default display.

**Figure 3.3 A.**

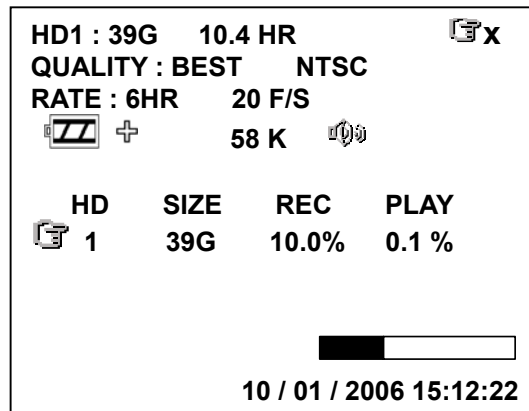

**(HD1: 39G)**: Total capacity of installed hard disk, 39 GB.

**(10.4 HR)**: Total 10.4 hour recording time available.

**( )**: Alarm record activated.

**(QUALITY: BEST)**: Record quality setting, BEST.

**(NTSC)**: The NTSC system.

**(RATE: 6 HR)**: Setting of Record time mode, 6 hours.

**(20 F/S)**: Record speed setting, 20 frames/sec.

**( )**: The current voltage.

**( )**: Audio function has been activated.

**( )**: Indicates which HDD is activated.

**(58K)**: The image file size.

**( HD )**: Hard disk compartment .

**( SIZE 39G)**: The capacity of the installed hard disk.

**( REC )**: Percentage of the system recording position.

**( PLAY )**: Percentage of the system playback position.







**( )**: External signal.

**( )**: Cannot operate now. For example, if you press the SETUP, SEARCH, REW and FF buttons during the recording mode, the icon will appear.

### 2.3.2 Channel Selection

The CH1, CH2, CH3, CH4, and Quad ( ) buttons are used to select single video channels

and the quad mode. The following table shows the functions under a different mode.

Mode	Split	Key	Result Display
Live / Record / Playback	4 CH	Quad (  )	
		CH1/ CH2/ CH3/ CH4	<input type="checkbox"/> ( Single channel )
	3 CH	Quad (  )	
		CH1/ CH2/ CH3	<input type="checkbox"/> ( Single channel )
	2 CH	Quad (  )	
		CH1/ CH2/	<input type="checkbox"/> ( Single channel )

## 2.4 Updating the System Software

Please take the following steps to safely update the system software.

1. Turn off the MDR-304.
2. Insert the SD card into the built-in SD slot of the unit.
3. Turn on the MDR-304.
4. The MDR-304 sounds a tone and displays the message “**XXXXXX BYTES READ**”. Now the MDR-304 is updating the system software, which will take approximately 90 seconds to process.
5. The MDR-304 displays the message “**PLEASE REMOVE SD CARD**”. The process is complete. Please remove the SD card, and the MDR-304 will restart automatically ( if you have already followed procedures 1 ~ 5 and the unit is still unable to turn on, then please first check if the SD card you are

using is functioning and the file is intact. Then start procedures 1 ~ 5 all over again.)

6. Verify the version of the system software (please refer to the section **4.6 VERSION** option).

### Caution:

1. Before carrying out the updating procedures, please ensure the SD card is working and the file of the system software is intact.
2. Don't Interrupt the process while the unit is updating itself, as this will cause the unit to crash.

# 3. OPERATIONS

This section shows how to configure and operation the MDR-304.

## 3.1 Configuring the Recording Settings

Recording time will vary depending on the image size, recording rate, and the capacity of the hard-disk drive. Generally, the MDR-304 comes with a built-in hard-disk drive for continuous recording from one to four weeks under most recording conditions. The table below shows the possible recording times based on a 20GB hard-disk drive at certain refresh rates and the corresponding image quality. With one or more hard-disk drive(s) in operation, please calculate the recording time using the table below in accordance with your requirements. For an NTSC unit, for example, if the unit is set to record images with **BEST** quality at a **30 fps** record rate,

normally a 20GB hard-disk drive will be filled in 3.7 hours (see the gray area in the table). If the total capacity of 80GB hard-disk drive is in use under the same refresh rate and picture quality, it will be filled in 14.8 hours (4 times the rate of a 20GB hard-disk drive).

**NOTE:**

1. Recording times are estimated in the tables below. For the actual available recording time of a recording configuration, please refer to the system information of the MDR-304. (Please refer to section 2.3 system information for more details.)
2. There is no audio function at the refresh rate in NTSC: 2.7 frames/sec ~ 1 frame/ 16 sec .  
There is no audio function at the refresh rate in PAL: 2.7 frames/sec ~ 1 frame / 16 sec.

NTSC (Audio OFF)		Possible Recording Time HDD=20GB ( hour )										
Image Quality	BEST	3.7	6	9	15	33.1	75.3	147.6	256.1	726.3	1088	1449.7
	HIGH	4.5	7.2	10.8	18	39.7	90.4	177.2	307.4	871.6	1305.6	1739.7
	STANDARD	5.6	9	13.5	22.6	49.7	113.0	221.5	384.2	1089.5	1632.1	2174.6
	BASIC	7.5	11.3	16.9	28.2	62.1	141.2	276.9	480.3	1361.9	2040.1	2718.3
Refresh Rate (Frame/Sec)		30	15	10	6	2.7	1.2	0.61	0.35	1/8	1/12	1/16

NTSC (Audio ON)		Possible Recording Time HDD=20GB ( hour )										
Image Quality	BEST	3.7	6	8.9	14.7	-	-	-	-	-	-	-
	HIGH	4.5	7.2	10.6	17.6	-	-	-	-	-	-	-
	STANDARD	5.6	9	13.2	21.8	-	-	-	-	-	-	-
	BASIC	7.5	11.3	16.5	27.1	-	-	-	-	-	-	-
Refresh Rate (Frame/Sec)		30	15	10	6	2.7	1.2	0.61	0.35	1/8	1/12	1/16

# OPERATIONS ( continued )

PAL (Audio OFF)		Possible Recording Time HDD=20GB ( hour )										
Image Quality	BEST	3.8	6	9	15	27.1	51.2	99.4	171.8	605.8	907.2	1208.6
	HIGH	4.5	7.2	10.8	18	32.5	61.4	119.3	206.1	726.9	1088.6	1450.3
	STANDARD	5.7	9	13.5	22.6	40.6	76.8	149.1	257.7	908.7	1360.8	1812.9
	BASIC	7.7	11.4	17.1	28.5	51.3	97	188.4	325.5	1147.8	1718.9	2290.0
Refresh Rate (Frame/Sec)		25	12.5	8.3	5	2.7	1.4	0.76	0.44	1/8	1/12	1/16

PAL (Audio ON)		Possible Recording Time HDD=20GB ( hour )										
Image Quality	BEST	3.8	6	8.9	14.7	-	-	-	-	-	-	-
	HIGH	4.5	7.2	10.6	17.6	-	-	-	-	-	-	-
	STANDARD	5.7	9	13.2	21.8	-	-	-	-	-	-	-
	BASIC	7.7	11.4	16.7	27.4	-	-	-	-	-	-	-
Refresh Rate (Frame/Sec)		25	12.5	8.3	5	2.7	1.4	0.76	0.44	1/8	1/12	1/16

**NOTE:**

If the HDD capacity is 1000KByte (1MB), the file size of 1fps (video) is 30KByte, and the file size of audio is 22Kbyte.

	5fps with audio	5fps without audio	25fps with audio	25fps without audio
<b>File Size</b>	172 (5FPS X 30KByte+22KByte)	150(5FPS X 30KByte)	772(25fps x 30KByte +22KByte)	750(25fps x 30KByte)
<b>Recording Time</b>	5.953488372	6.826666667	1.32642487	1.365333333

## 3.2 The Recording Operations

This section details the way to record video into a hard-disk drive. Before commencing with the recording function, please configure the recording setting properly according to your needs.

### 3.2.1 Manual Recording

Take the following steps to start and stop recording:

- (1) Press the **REC** button to record video into a hard disk drive with the corresponding programmed recording settings. The **REC** button will light up indicating the MDR-304 is in the recording status.
- (2) Press the **STOP** button to stop recording any time.
- (3) To access just recorded video, please refer to section 3.4 for more details.

### 3.2.2 Alarm Recording

Take the following steps to activate the programmed alarm recording. For the **ALM OPERATION**, **REC RATE**, **REC QUALITY**, **AUDIO**, **ALM TYPE**, **ALM DURATION**, and **PRE-ALARM** settings, please refer to section 4.2 for more details.

- (1) Press the **SETUP** button to enter the **MAIN MENU**.
- (2) Select **ALARM** and press the **Enter** button to enter **ALARM**.
- (3) Set the desired **REC RATE**, **REC QUALITY**, **ALM TYPE**, and **ALM DURATION** for use. If the audio function is required, set **AUDIO** to **ON**. If pre-alarm recording is required, set **PRE-ALARM** to **ON**.
- (4) To activate/deactivate the alarm recording, set **ALM OPERATION** to **ON/ OFF**.

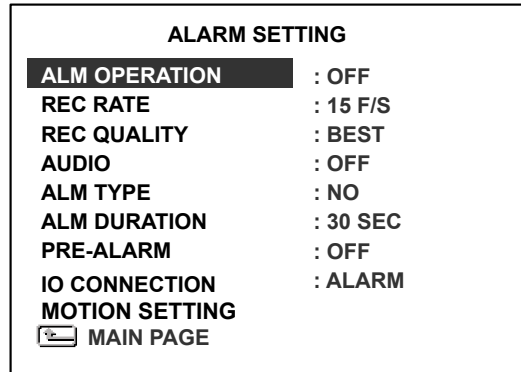
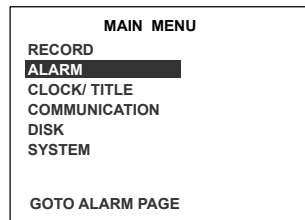

### 3.2.3 Externally Triggered Recording

By connecting the **ALARM IN** of ALARM I/O on the rear panel of the MDR-304, you can activate / deactivate the alarm recording function of a MDR-304. The file will be kept with a prefixed "A".

**NOTE:** The status of recording operations when an alarm takes place is shown in the diagrams below.

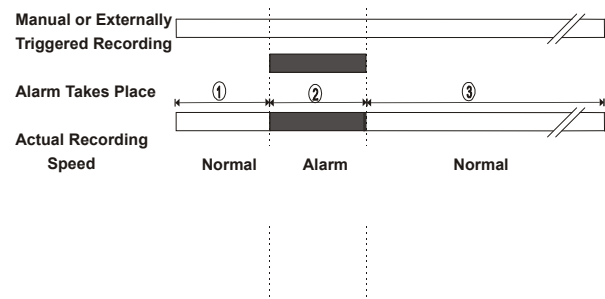

## 3.3 The Playback Operations

This section shows you how to operate the fast, slow, and single-picture playback functions, and details how the unit is to playback a file in a different operation status. Please refer to the following paragraphs specifying the relevant details. When playing a file, the monitor should display a flashing **PLAY** message and the **PLAY** button will light up indicating that the MDR-304 is in the playback status.

To switch between channels 1–4 and the quad view in the playback mode, please press the **CH1**, **CH 2**, **CH 3**, **CH4** and  buttons.

**NOTE:** When you press the "PLAY" button to enter the play mode, you then press the "SEARCH" button to change the two audio sources to any one or two of the cameras you have.

### 3.3.1 Normal Playback

Once the user presses the PLAY button, the MDR-304 will start to playback the recorded data at the recorded speed; the starting position must be fixed according to different operation sequences.

**A. Play back from the latest record in the STOP position.**

[ PLAY ] - [ STOP ] - [ PLAY ]

**B. Play back from the latest recorded video.**

[ REC ] – [ REC Stop ] – [ PLAY ]

**C. Play back from a video clip in the Search List.**

[Search] – [ PLAY ]

**D. Play back from the beginning of a hard disk's recorded data.**

[STOP – press the key for 3 sec. ] – PLAY

Once playback reaches the end of an HDD's recorded data, the MDR-304 will show the ending message ( use the **SEARCH** functions or rewind to replay the file if required ).

### 3.3.2 Fast Forward/Backward

There are **7** speeds available for playback: 1x, 2x, 4x, 8x, 16x, 30x and 100x

While playing back recorded video at the recorded speed:

**Forward:** Press the **FF** button to view the recorded video in the forward direction at a speed faster than the recorded speed or to return to the normal speed of playback. Each subsequent pressing of the **FF** button to the right increases the forward rate, as 2x, 4x, 8x, 16x, 30x and 100x.

**Backward:** Press the **REW** button to view the recorded video in the reverse direction at a speed faster than the recorded speed or to return to the normal speed of playback. Each subsequent pressing of the **REW** button to the left increases the reverse rate, as -1x, -2x, -4x, -8x, -16x, -30x and -100x.

### 3.3.3 Slow Forward/Reverse

There are **4** speeds available for a slow playback: 1/2, 1/4, 1/8, and 1/16.

While playing back recorded video at the recorded speed:

(1) Press the **PAUSE** button for the slow playback mode.

(2) **Forward:** Press the **FF** button to view the recorded video in the forward direction at a speed slower than the recorded speed. Each subsequent pressing of the **FF** button to the right increases the forward rate, as 1/2, 1/4, 1/8, and 1/16.

(3) **Reverse:** Press the **REW** button to view the recorded video in the reverse direction at a speed slower than the recorded speed. Each subsequent pressing of the **REW** button to the

left increases the reverse rate, as  
-1/2, -1/4, -1/8, and -1/16.

- (4) **Normal:** Press the **PLAY** button to return to the normal speed of playback.

### 3.3.4 Play back picture-by-picture

While playing back recorded video at the recorded speed:

- (1) Press the **PAUSE** button for the pause mode.
- (2) Press the **PAUSE** button to display one frame of a picture at a time in the forward direction ; however, the **PAUSE** button can only function in a forward direction.
- (3) Press the **PLAY** button to return to the normal speed of playback.

## 3.4 The Search Operations

This section shows you how to access recorded video.

### 3.4.1 The FULL LIST Search

Take the following steps to proceed with the full-list search function.

- (1) Press the **SEARCH** button to enter the search mode.
- (2) Select the **FULL LIST** and press the **Enter** button to access the complete list of recorded video.
- (3) Highlight the specific recorded video of your requirement and press the **Enter** button to display the selected video.

**(Key Operation: Press the “^” and “v” buttons to select a video; press the “<” and “>” buttons to flip over a page.)**

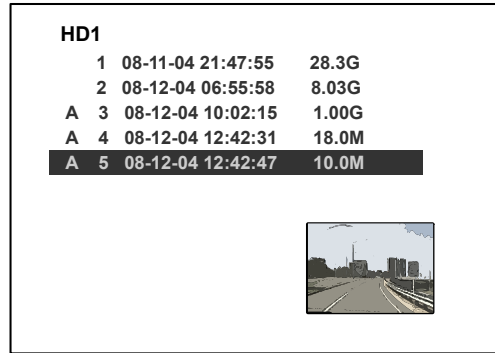
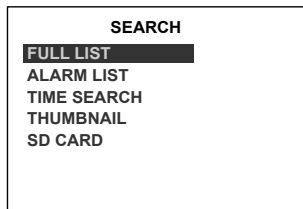

**NOTE: A: Alarm recording.**

**NOTE: The maximum number of index items in the list in a hard disk drive is 3000.**

### 3.4.2 The ALARM LIST Search

Take the following steps to proceed with the alarm-list search function.

- (1) Press the **SEARCH** button to enter the search mode.
- (2) Select the **ALARM LIST** and press the **Enter** button to access the complete list of alarm-event recorded video.
- (3) Highlight the specific recorded video of your requirement and press the **Enter** button to display the selected video.

**(Key Operation: Press the “^” and “v” buttons to select a video; press the “<” and “>” buttons to flip over a page.)**

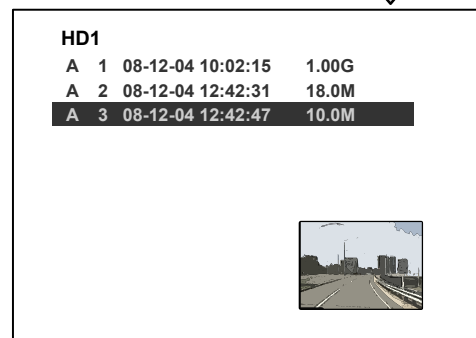
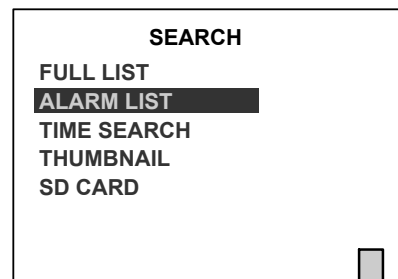

### 3.4.3 The TIME Search

Take the following steps to proceed with the time-list search function.

- (1) Press the **SEARCH** button to enter the search mode.
- (2) Select the **TIME SEARCH** and press the **Enter** button to access the time-setting page.
- (3) Set the time period you wish to search for the recorded video.
- (4) Press the **Enter** button to start searching and displaying the concerned image.
- (5) If no video is found, please return to the time-setting page and repeat steps (3) and (4) for another search.

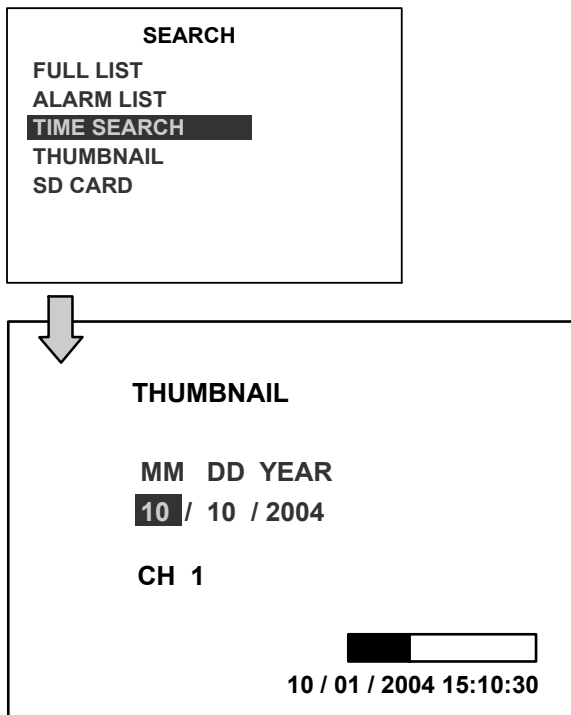

### 3.4.4 The THUMBNAIL Search

Take the following steps to proceed with the thumbnail search function.

- (1) Press the **SEARCH** button to enter the search mode.
- (2) Select **THUMBNAIL** and press the **Enter** button to access the thumbnail page.
- (3) Set the date you wish to search for a

recorded video.

- (4) Press the **Enter** button to start searching for and displaying an image.

**Note:** You can select the image by using the "<", ">", "▲", and "▼" buttons to move the focus.

- (5) There are **5** levels of recording time modes to choose from: **1 Hour, 10 Minutes, 1 Minute, 10 Seconds** and **1 Second**. Select the specific frame you require and press the **Enter** button to enter the next level. If you want to return to the previous level, please press the **Setup** button.
- (6) Once you reach the critical point at any level, you can start to playback by just clicking the **PLAY** button.

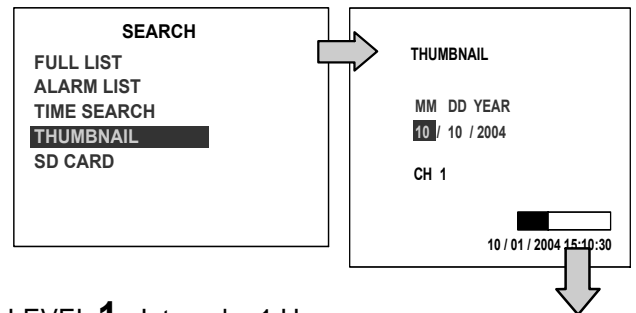

LEVEL 1 : Interval = 1 Hour



LEVEL 2 : Interval = 10 Min.





**LEVEL 3** : Interval = 1 Min



**LEVEL 4** : Interval = 10 Sec.



**LEVEL 5** : Interval = 1 Sec.



**3.4.5 The SD CARD Search**

Take the following steps to proceed with the SD card search function.

- (1) Insert an SD Card into the SD card slot of the front unit.
- (2) Press the **SEARCH** button to enter the search mode.
- (3) Select the **SD CARD** and press the **Enter** button to access the complete list of JPG files.

- (4) Highlight the specific JPG file you require and press the **Enter** button to display the image.
- (5) If you need another image, please return to the SD card JPG file list page and repeat steps 3 and 4 for another search.

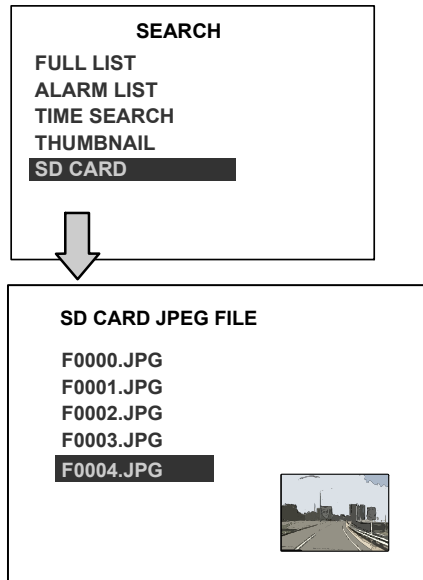

**NOTE:** To delete a JPG file in the SD card, please return to the SD CARD JPG FILE list page, highlight the specific JPG file and press the Setup button, then select "Yes" to delete the image.

## 3.5 The Backup Operations

### 3.5.1 The SD Card Backup Operations

The SD card slot of the front unit has four functions as shown below:

#### 3.5.1.1 Archive single image clips into an SD card

Please take the following steps to archive a critical image in an SD card.

- (1) Press the **SETUP** button to enter the setup mode and select **DISK**.
- (2) Highlight **DISK** and press the **Enter** button to enter the **DISK SETTING** page.
- (3) Then set **SD FILE** to **JPEG**.
- (4) Insert an SD card into the SD card slot of the front unit.
- (5) Start playing back the recorded video.
- (6) Press the **PAUSE** button to freeze the desired pictures.
- (7) Press the **SETUP** button to save the image in the SD Card.

The quantity of pictures that can be stored depends on the SD card capacity. You can have the saved images printed out in any computer. The image is stored in the compressed JPEG format. If more than one clip is stored in an SD card, the file names will be assigned in sequence as shown below.

**SAVE TO F000.JPG**

**SAVE TO F0001.JPG**

...

**SAVE TO F000N.JPG**

- (8) The saved picture is the same as the present picture on the screen; please use the CH1, CH2, CH3, CH4, and **Quad** buttons to switch to the channel(s) desired, and then press the **SETUP** button to save.

#### 3.5.1.2 Archive video of AVI clips into an SD Card

Please take the following steps to archive a critical video in an SD card.

- (1) Press the **SETUP** button to enter the setup mode and select **DISK**.
- (2) Highlight **DISK** and press the **Enter** button to enter the **DISK SETTING** page.
- (3) Now set **SD FILE** to **AVI**.
- (4) Insert an SD Card into the SD card slot of the front unit.
- (5) Start playing back the recorded video.
- (6) Press the **PAUSE** button to freeze the pictures you want
- (7) Press the **SETUP** button to save the video in the SD card.

The quantity of video that can be stored depends on the SD card's capacity. The image is stored in the compressed AVI format. If more than one clip is stored in an SD card, the file names will be assigned in sequence as shown below.

**SAVE TO M0000.AVI**

**SAVE TO M0001.AVI**

...

**SAVE TO M000N.AVI**

#### NOTE:

- The **JPEG** file format can be played and deleted in the **MDR-304**. Please refer to section 3.4.5.
- The **AVI** file format cannot be played and deleted in the **MDR-304**. It can only be played in a card reader connected to a computer.
- The file format can be selected from the "SD FILE" item on the Setup Menu. Please refer to section 4.5 for more details.

#### Backup the system setting info into an SD card.

The MDR-304 offers a quick setup method by using an SD card. If a user wants to set many MDR-304 devices with the same settings, the MDR-304 can save the whole setting in the SD card, and then transfer it to another MDR-304.

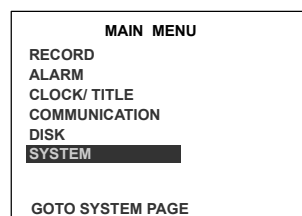

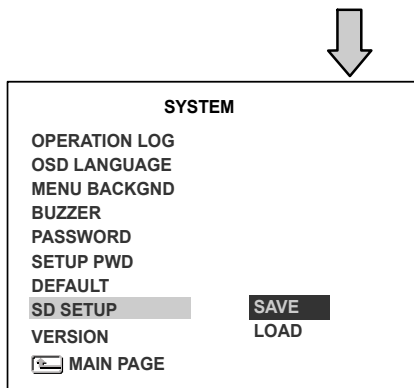

#### Save the whole setting into the SD card:

- Insert an SD card into the SD card slot.
- Press the **SETUP** button to enter the setup mode.
- Highlight **SYSTEM** and press the **Enter** button to enter the **SYSTEM SETTING** page.
- Set **SD SETUP** to **SAVE**. Then the system setting information will be automatically saved in the SD card.

#### Transfer the system setting info of the MDR-304 to another MDR-304:

- Insert the SD card which has stored the system setting information into the MDR-304.
- Press the **SETUP** button to enter the setup mode and select **SYSTEM**.
- Highlight **SYSTEM** and press the **Enter** button to enter the **SYSTEM SETTING** page.
- Then set **SD SETUP** to **LOAD**.

#### 3.5.1.4 Updating the System Software

Please refer to section **4.6** for more details.

## 3.6 The Key Lock Operation

The Key lock operation protects the unit against unauthorized use by disabling the entire front panel controls. Press the **Enter** button for at least 3 seconds to lock the unit; to release the **Key Lock**, press the button again and enter the pre-set password (or the standard password if this is the initial setting).

# 4. MENU SETUP

## 4. MENU SETUP

There are **6** categories for operation setting in the setup menu system as shown below. The following sections will instruct you step by step to configure the operation settings and state each menu's purpose and options. Press the **Setup** button to access the setup menu. Once inside the menu system, the on-screen menu allows you to set up the key features of the unit. The functions of various buttons within the menu-setup mode are described in the paragraphs below.

### KEY FUNCTIONS

#### Setup button:

Press to enter the setup menu. Press again to exit the setup mode.

#### The “▲” and “▼” buttons:

Press to select the desired item or entry for setting.

#### The “<” and “>” buttons:

Press to highlight the desired option or to select the context for setting.

#### The Enter button:

Press to enter the selected item and to save the setting.

### 4.1 The REC Setting

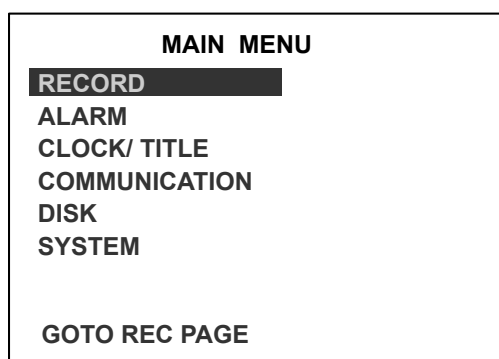

This page allows you to set the recording rate and recording quality, and enables you to continue

recording when the disk is full.

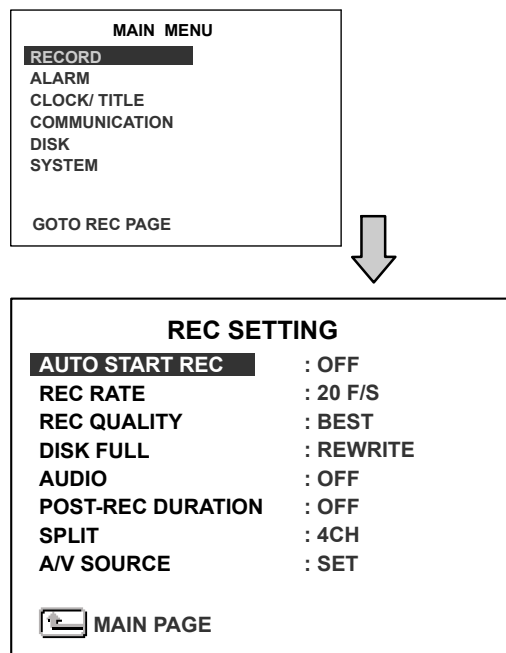

#### AUTO START REC:

This option is for setting the start-recording function while powering on the MDR-304.

**OFF:** Inactivate the function.

**0 SEC:** Start recording immediately when turning on the MDR-304.

**1 MIN:** Start to record after powering on the MDR-304 for 1 minute.

#### REC RATE:

This option is for adjusting the number of pictures recorded every second into a storage disk. The recording rate controls the frequency at which the number of video pictures can be recorded.

- For an NTSC unit, there are 11 different recording rates you can select from: **30F/S (30 frames per second)**, **15F/S**, **10F/S**, **6F/S**, **2.7F/S**, **1.2F/S**, **0.61F/S**, **0.35F/S**, **1 F/8S**, **1F/12S**, and **1F/16S**.
- For a PAL unit, there are 11 different recording rates you can select from: **25F/S (25 frame per second)**, **12.5F/S**, **8.3F/S**, **5F/S**, **2.7F/S**, **1.4F/S**, **0.76F/S**, **0.44F/S**, **1 F/8S**, **1F/12S**, and **1F/16S**. Please refer to the table in section 3.1 for details.

## REC QUALITY:

This option determines the image quality to be recorded. The MDR-304 stores images in the compressed format and allows the image quality to be altered by the image size. There are 4 levels of image quality you can select from: **BEST, HIGH, STANDARD, and BASIC**. Selecting the BEST image for use provides higher-resolution recorded images, and normally takes up more storage space than a HIGH, STANDARD or BASIC image does.

## DISK FULL:

This option determines the way to utilize storage media in case of a full disk.

**REWRITE:** When the hard disk is full, the device continues recording by displacing the old data.

**STOP:** When the hard -disk is full, the device will stop recording.

## AUDIO:

This option determines the way to record sound if necessary.

**OFF:** Disables the AUDIO recording.

**11KHZ:** Enables the AUDIO recording and records at the 11KHz sampling rate.

**22KHZ:** Enables the AUDIO recording and records at the 22KHz sampling rate.

**NOTE:** The audio function can only be activated in the following refresh rates in NTSC(PAL): 30(25), 15(12.5), 10(8.3), 6(5),and 2.7(2.7) frames/sec.

## POST-REC DURATION:

(Functional in "Pin connections with the ignition key" only, refer to section 1.5.7)

After the ACC is powered off (ACC OFF), the MDR-304 will record continuously, obeying the time which is set in the "POST-REC DURATION" time until that time period is over. If the user enables (activates ON) the "ALM OPERATION" and the motion detection functions, the MDR-304 will not start the post-recording and will only start recording when a motion alarm is triggered in the

"POST-REC DURATION" time. If the user disables (activates OFF) the motion detection function, the MDR-304 will record continuously until the "POST-REC DURATION" time is over.

**Note: When the motion detection function is enabled, the MDR-304 will not start the post-recording.**

This option determines the duration of the post-recording time after the ACC is turned off. There are 9 options here you can select from: **OFF, 1 MIN, 5 MIN, 10 MIN, 30 MIN, 60 MIN, 90 MIN, 120 MIN and NON STOP.**

**OFF:** The recording will stop automatically when the vehicle motor is turned off.

**1 MIN:** There will be automatic recording for a minute after the vehicle motor is switched off.

**5 MIN:** There will be automatic recording for five minutes after the vehicle motor is switched off.

**10 MIN:** There will be automatic recording for ten minutes after the vehicle motor is turned off.

**30 MIN:** There will be automatic recording for thirty minutes after the vehicle motor is turned off.

**60MIN:** There will be automatic recording for one hour after the vehicle motor is turned off.

**90 MIN:** There will be automatic recording for 90 minutes after the vehicle motor is turned off.

**120 MIN:** There will be automatic recording for 120 minutes after the vehicle motor is turned off.

**NON-STOP:** This option allows for continuous recording after a vehicle's motor has been switched off. However, its functioning depends on the amount of power the vehicle has available to it, so it can run only as long as there is power. Enough power will be left untapped by this option to turn the vehicle motor on the next time the user starts it.

**Note: If the voltage is less than 10.4 volts, the battery is in the "Too low" mode", and the MDR-304 will automatically power off and there will be a problem in starting the engine in case of a small - scale car.**

## SPLIT:

This option determines the layout of the screen. You can select from **4CH, 3CH, and 2CH**. The resulting layout on the screen will be as follows.

**4 CH:** This option splits the screen in the quad mode.

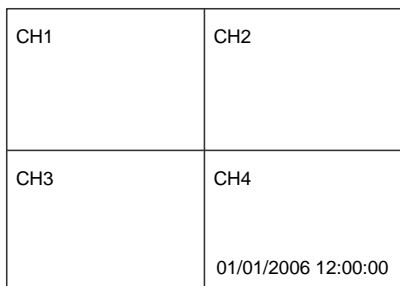

**3 CH:** This option splits the screen in three channels.

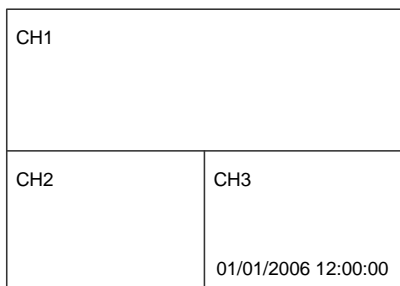

**2 CH:** This option splits the screen in two channels.

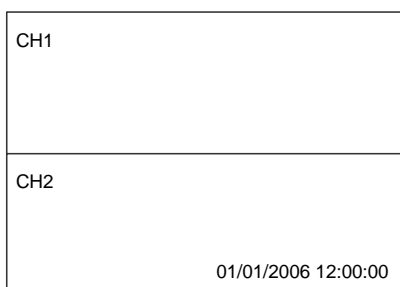

**A/V SOURCE:**

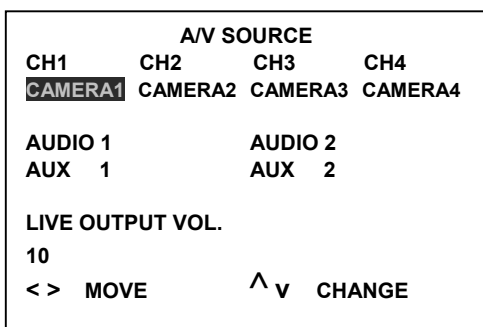

This page determines the video and the audio source. Choose the channel and the audio/ video numbers you want to see. Only four channels are available, each with four video inputs and four video outputs which you can select from and set; these same four channels have six audio inputs and two audio outputs you can select from and set. This "A/V SOURCE" page lets you set two audio outputs: AUDIO 1 and 2, which have six microphone sources each which you can choose from, four from the video cameras and two from the AUX ( auxiliary )

microphones. You can only set two microphones to play. Each of the ports, AUDIO 1 and 2, can play the sound recordings of the same or different videos simultaneously.

**LIVE OUTPUT VOL.:** This item determines the output volume levels in the live mode. The options range from "00" (mute) to "10" (full).

## 4.2 The ALARM Setting

This menu allows users to program the configuration of the alarm recording only when an alarm input is activated. The device will record as long as the alarm input is activated.

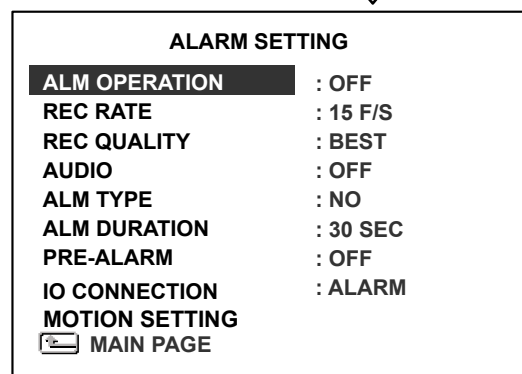
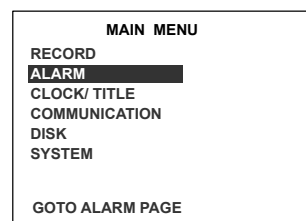

**ALM OPERATION:**

This option determines whether to activate/deactivate the alarm recording when it detects an alarm input.

**ON:** The device activates the alarm recording when it detects an alarm input.

**OFF:** The device ignores the alarm signal when it detects an alarm input.

**REC RATE:**

This option is for the purpose of adjusting the number of pictures recorded every second into a storage disk when an alarm input is activated. For an NTSC unit, there are 5 different record speeds you can select from: **30F/S (30 frames per second)**, **15F/S**, **10F/S**, **6F/S**, and **REMAIN**. For a PAL unit, there are 5 different record speeds you can select from: **25F/S (25 frames per second)**, **12.5F/S**, **8.3F/S**, **5F/S**, and **REMAIN**. If you select **REMAIN** for use, the device will record images at the same speed as set on the **REC** page.

**REC QUALITY:**

This option determines the image quality to be recorded when an alarm input occurs. There are 4 levels of image quality to choose from: **BEST**, **HIGH**, **STANDARD**, and **BASIC**. The table below shows the level of image quality with the corresponding compression ratio and image size.

REC Quality	Best	High	Standard	Basic
Image Size	60KB	50KB	40KB	32KB

**AUDIO:**

This option determines the way to record sound if or as necessary.

**OFF:** Disables the AUDIO recording.

**11KHZ:** Enables the AUDIO recording and records at the 11KHz sampling rate.

**22KHZ:** Enables the AUDIO recording and records at the 22KHz sampling rate.

**NOTE:** The audio function can only be activated in the following refresh rates in NTSC(PAL): 30(25), 15(12.5), 10(8.3), and 6(5) frames/sec.

**ALM TYPE:**

This option allows users to set a type of alarm input corresponding to the sensor signal in use.

**NO:** Normally Open. This is to be used with the type of alarm sensor whose contact remains open in normal conditions and closes in case of activation.

**NC:** Normally Closed. This is to be used with the type of alarm sensor whose contact remains closed in normal conditions and opens in case of activation.

**ALM DURATION:**

This option allows users to set alarms for a certain duration. You can select one of the six following options: **0 SEC**, **30SEC**, **1 MIN**, **5 MIN**, **10 MIN**, and **NON-STOP**.

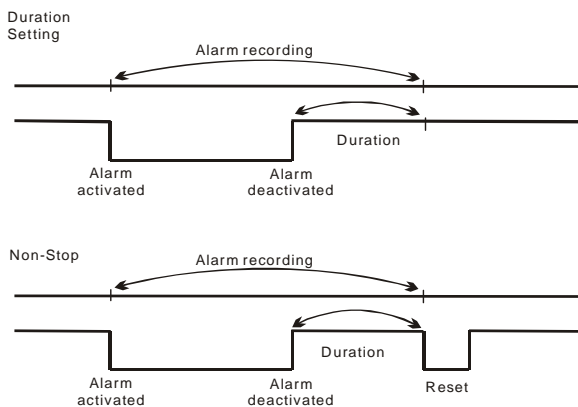

**PRE- ALARM:**

This option determines that images before an alarm occurs will be recorded in the hard-disk drive. When an alarm is triggered the device will record the image prior to the alarm for 50 images. (10 frame/ sec)

**ON:** Enables this function.

**OFF:** Disables this function.

**NOTE:** If the device is already in the recording mode before an alarm occurs, the pre-alarm recording will not take effect.

**I/O CONNECTION:**

This item is for the setting of the I/O connection. ( Please ref. to 1.7 ) Here you have two options of determining your connection.

**ALARM:** This item connects you with an alarm sensor. Set the 4 inputs of the I/O connection as ALM1/ ALM2/ ALM3/ RESET. The Alarm signals are used to trigger the alarm recording.

**VEHICLE SIGNAL:** Set the 4 inputs of the I/O connection as LEFT/ RIGHT/ not applicable / BRAKE. The vehicle signals will be recorded with the video data.

**MOTION SETTING:**

The **motion detection** function is only activated in the mode of "**ACC OFF**".

(Please refer to section "4.1" and "4.7".)

When the **motion detection** function is enabled, the MDR-304 will not start the post-recording. The MDR-304 will only start recording when the **motion detection** is triggered and will obey the time which is set under "**ALM DURATION**" until that time period is over. Before using the motion detection function, please turn the **CH1/ CH2/ CH3/ CH4** options as **ON**, and set the **SENTIVITY** (1 ~ 5 ) to a suitable value.

**MOTION SETTING**

**CH1** : ON

**CH2** : OFF

**CH3** : OFF

**CH4** : OFF

**SENSITIVITY** : 3

**MAIN PAGE**

**SET CH1 MOTION DETECTION ON/OFF**

### CH1/ CH2/ CH3/ CH4 :

These options enable /disable the motion detection.

**ON** : Enables the motion detection.

**OFF**: Disables the motion detection.

### SENSITIVITY:

This option allows users to set the motion sensitivity.

1 is the most sensitive setting. 5 is the least sensitive setting.

**US**: Daylight saving time begins at 2:00 a.m. on the first Sunday of April. The time reverts to standard time at 2:00 a.m. on the last Sunday of October.

**EUROPE**: ( Except UK ) Daylight saving time begins at 2:00 a.m. on the last Sunday of March. The time reverts to standard time at 2:00 a.m. on the last Sunday of October.

**UK**: Daylight saving time begins at 1:00 a.m. on the last Sunday of March. The time reverts to standard time at 1:00 a.m. on the last Sunday of October.

**SET**: This sets the beginning and the end of the daylight saving time.

## 4.3 The CLOCK/ TITLE Setting

This option allows you to set the system time, the daylight saving time and the power delay time. This option also allows users to set the titles for each video source or camera, in live or recording mode.

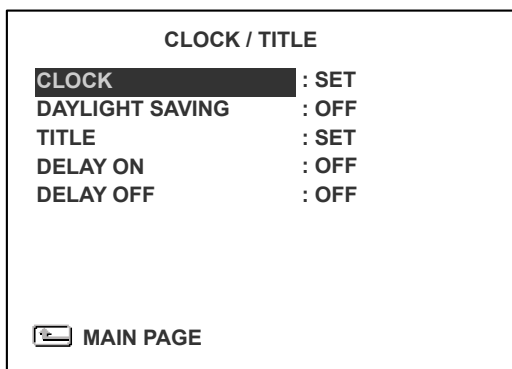
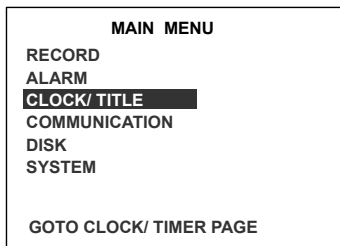

### CLOCK:

This entry allows users to set the system time.

**NOTE**: The clock data is retained for about 3 months after the 15-hour power supply is used up (in the Operate On mode).

### DAYLIGHT SAVING

This entry allows users to set the daylight saving time.

**OFF**: This disables the daylight saving time.

### TITLE:

This entry allows users to set the titles for each video source or camera, in live or recording mode; press the DISPLAY button to switch on the display status to show the titles. The maximum length for each title is 24 letters.

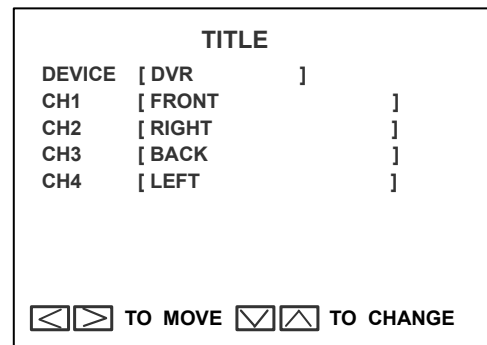

### DELAY ON:

This entry sets the delay time of the relay on after the MDR-304 powers up. The selectable options are **OFF, 0 SEC, 1 MIN, 5 MIN and 10 MIN**

### DELAY OFF:

This entry sets the delay time of the relay off after the MDR-304 powers off. The selectable options are **OFF, 1 MIN, 5 MIN, 10 MIN, 30 MIN, 60 MIN and NON STOP.**



## 4.4 The COMMUNICATION Setting

Please refer to **6.1 RS-232 Protocols** for more details.

MAIN MENU

RECORD  
ALARM  
CLOCK/ TITLE  
**COMMUNICATION**  
DISK  
SYSTEM

GOTO COMM PAGE

COMM SETTING

**COMM ID** : 0 1  
RS232 ENABLE : ON  
RS232 CONNECTION : DATA BOX  
BAUD : 9600  
GPS SPEED : Km/H

MAIN PAGE

### COMM ID:

This is the Communication ID for the RS232 communication. After the MDR-304 receives a RS232 command, it checks if the <Dest ID> within the code is the same as the COMM ID, in which case the particular command can be accepted.

### RS-232 ENABLE:

The RS-232 communication port can be either in an importing or exporting mode according to your applications.

**ON:** This enables the RS-232 communication port. When you wish the unit to be controlled by an external device, please select this entry for use.

**OFF:** This disables the RS-232 communication port.

### RS-232 CONNECTION:

This item lets you control the following:

**GPS:** Use the GPS connector with the GPS receiver.

**Note:** Refer to 1.5.4 for more information about the correct pin assignment.

**DATA BOX:** Use the DATA BOX connector if the mobile MDR-304 is compatible with it. Use it if you want to connect only with the RS 232 port directly without using the GPS connectors.

**Note:** You can select only one of the functions between **GPS** or **DATA BOX** simultaneously.

### BAUD:

This entry selects the baud rate of the RS232 port. The selectable options are **2400, 4800, 9600, 19200, 28800, 38400, 57600** and **115200**.

### GPS SPEED:

Please select the **Km/H** (kilometers per hour) or **MPH** (miles per hour) to meet your requirement.

## 4.5 The DISK Setting

MAIN MENU

RECORD  
ALARM  
CLOCK/ TITLE  
COMMUNICATION  
**DISK**  
SYSTEM

GOTO DISK PAGE

DISK SETTING

**HD REFORMAT** : HD1  
HD FAT32 : BUILD  
SD FILE : JPEG  
AUTO ERASE : OFF  
SD REFORMAT : START  
GPS STAMP : OFF

MAIN PAGE

### HD REFORMAT:

This option allows you to clear out all the data in the hard-disk drive. You will be required to enter the pre-set password before proceeding with clearing out the data. Enter the standard password “**9999**” if you haven’t set your individual password. To set your individual password, please refer to the section **4.6 System Setting - PASSWORD** option.

**HD 1:** Clears out all the data stored in HD 1.

### HD FAT32:

This function builds the FAT32 file system in the hard disk, so the data in the hard disk can be played back in a PC.

### SD FILE:

This option determines the format to save important image files in an SD card.

**JPEG:** Archives images in the JPEG format, to save a single picture in every file.

**AVI:** Archives images in the AVI format, to save a sequence of images in a file, the maximum limit being 300 images for every file. You can stop recording whenever you want, and if you don't, recording will automatically stop at the optimum of **300** images.

**NOTE:** To save images, please refer to section 3.5.1 for more details.

**AUTO ERASE:**

This item offers you two options.

**OFF:** Choosing this alternative disables the "AUTO ERASE" function.

**SET:** This choice enables the "AUTO ERASE" function. Select "SET" and press the ENTER button to enter the "AUTO ERASE SETTING" page, where you can enable the settings to save data for storage for any period of time from 1 to 365 days. After the expiry of the time period you set, the data will be erased automatically. This process of storage and erasure over the time period you set will be repeated indefinitely until you disable the settings or change the settings to a different time period.

**SD REFORMAT:**

This option allows you to clear out all the data in the SD Card.

**GPS STAMP:**

This option allows you to activate (ON) or deactivate (OFF) the GPS STAMP function.

**4.6 The SYSTEM Setting**

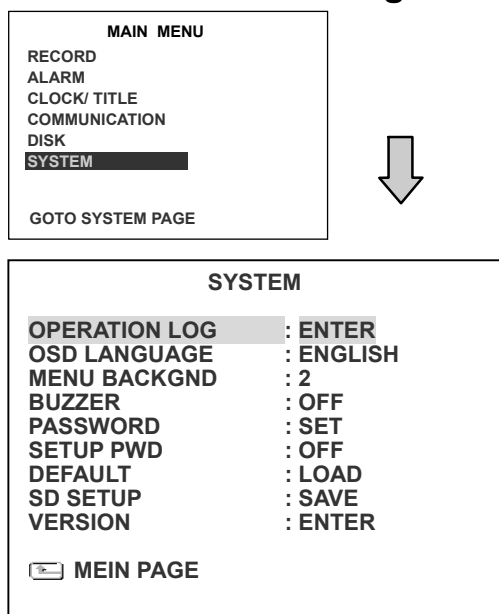

This page is used for accessing the history of the operation status, setting the password, resuming factory default, and determining the menu display background.

**OPERATION LOG:**

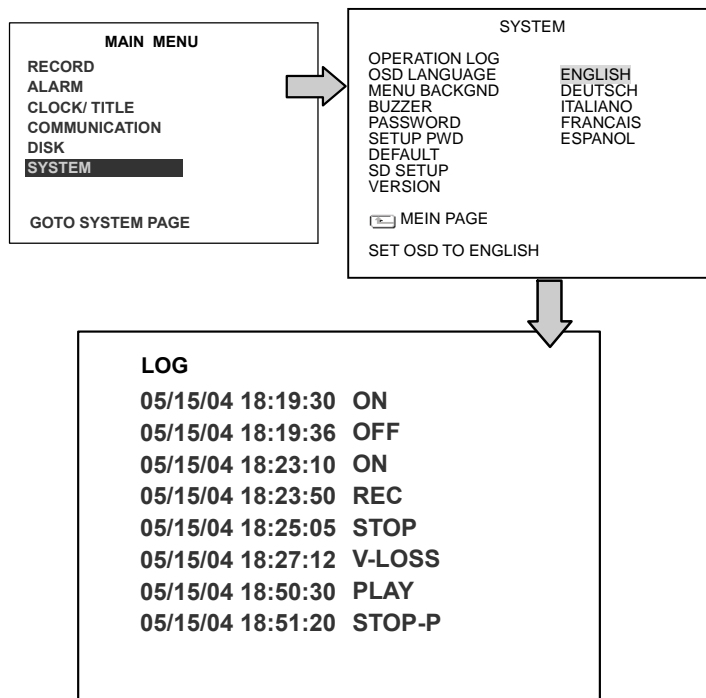

This log shows the history of the operation status in chronological order. What the following entries represent is detailed below.

- ON:** Powers on the device.
- OFF:** Powers off the device.
- REC:** Starts recording.
- STOP:** Ceases recording.
- STOP-P:** Ceases playback.
- PLAY:** Shows recorded video.
- V-IN:** Video input is connected.
- V-LOSS:** Video loss occurs.
- P-LOSS:** Power interruption occurs.
- A-IN:** Detects an alarm input.
- LOCK:** Disables the entire front panel controls.
- UNLOCK:** Releases the key lock.
- UPDATE:** Updates system software.
- ACC ON:** The Vehicle Ignition is ON.
- ACC Off:** The Vehicle Ignition is OFF.
- OFF-BL:** Power off because of the low voltage of the battery.
- OFF-BH:** Power off because of the high voltage of the battery.

**Note:** The log keeps an operation history on a revolving basis because of a limit of 4000. When the log is full, the newly registered record of an operation will replace the existing records starting with the oldest record.

**OSD LANGUAGE:**

You have an option which language to use.

**MENU BACKGND:**

There are **3** levels of background color transparency you can choose from: level 1 is totally transparent, level 3 is opaque, and level 2 is between levels 1 and 3. The background color is used in the setup menu and search functions.

**BUZZER:**

This option determines the embedded buzzer will sound a tone to signal the following situations. A tone lasts about two seconds long.

**ON:** Enables the buzzer.

**OFF:** Disables the buzzer.

---

**Situation**

---

Alarm occurs

Video loss occurs

Disk is full

Load factory default

Buzzer set to ON

Key lock function enabled/disabled

Power on /off mobile rack HDD

---

**PASSWORD:**

This option allows you to set a password to prevent any unauthorized re-formatting of the hard disk drive and to unlock the entire front panel button controls. The standard password is "9999".

**OLD PASSWORD:** Enter the pre-set password (or the standard password if this is the initial setting) to access the password setting system.

**NEW PASSWORD:** Enter a 4-digit-number password of your choosing which will replace the pre-set password (or the standard password "9999").

**SETUP PWD:**

When this option is on, the user must pass the password check before entering the setup menu.

**ON:** Enables the password protection for the setup menu.

**OFF:** Disables the password protection for the setup menu.

**DEFAULT:**

This option allows you to reload the factory default setting. Please do note that the password cannot be changed in the factory default setting.

**SD SETUP:**

The MDR-304 offers a quick setup method by using an SD card. If the user wants to set up a number of the same devices with the same settings, he can save the whole settings to an SD card, and then transfer them to another MDR-304.

**SAVE:** Saves the whole setting to the SD card.

**LOAD:** Loads the whole setting from the SD card.

**VERSION:**

This item is in the setup menu: it shows the BIOS version, the software version, the last updated date, and the software version of the keyboard and the rear board.

<b>VERSION</b>	
<b>SW</b>	<b>: 1.21</b>
<b>DATE</b>	<b>: Nov 10 2006</b>
<b>KEY</b>	<b>: 1.00</b>
<b>REAR:</b>	<b>1.09</b>

## 4.7 Notices of Motion and Alarm Setting

Before commencing with the alarm recording function, please configure the recording setting properly according to your needs. Take the following notices to activate the programmed alarm recording.

### ACC IGNITION ON:

During the processing (ACC ON), the MDR-304 will start the auto start recording function while powering on (refer to section 4.1), and may be manually recorded by the user (refer to section 3.2.1). To activate the alarm recording, please set the "**ALM OPERATION**" to "**ON**" in the "**ALARM SETTING**" page to enable the function. When an alarm is triggered, the device will record in the set alarm-recording rate.

### ACC IGNITION OFF:

1. After the ACC is powered off (ACC OFF), the MDR-304 will record continuously, obeying the time which is set in the "**POST-REC DURATION**" time until that time period is over. If the user enables (activates ON) the "**ALM OPERATION**" and the motion detection functions, the MDR-304 will not start the post-recording and will only start recording when a motion alarm is triggered in the "**POST-REC DURATION**" time. If the user disables (activates OFF) the motion detection function, the MDR-304 will record continuously until the "**POST-REC DURATION**" time is over.
2. The **motion detection** function is only activated in the mode of "**ACC OFF**".  
(Please refer to section 4.2, "The ALARM Setting", for more information.)
3. When the **motion detection** function is enabled, the MDR-304 will not start the post-recording. The MDR-304 will only start recording when the **motion detection** is triggered and will obey the time which is set under "**ALM DURATION**" until that time

period is over.

(Please take notice that if the "**POST-REC DURATION**" time is over, the MDR-304 will stop recording even if the "**ALM DURATION**" is set for a longer time period than the "**POST-REC DURATION**" time.)

4. After the ACC is powered off (ACC OFF), any externally triggered alarm will not influence the recording mode which you set. But the MDR-304 will calculate the time of the "**POST-REC DURATION**" anew in this situation.
5. When the "**POST-REC DURATION**" time is over while the "**DELAY OFF**" time is still going, the MDR-304 will not start the post-recording or the motion recording, and the external triggers will have no effect.

# 5. MISCELLANEOUS

## 5.1 The RS-232 Setup & Protocol

### 5.1.1 The RS-232 Protocol

Use a Null Modem cable (the standard RS-232 9 Pin Cable with Pin 2 and Pin 3 exchanged ; see the pin configuration chart below for details) to connect the rear panel of the MDR-304.

PIN NO.	PIN Assignment
1.	Not Connected
2.	RX
3.	TX
4.	Not Connected
5.	Ground
6.	Not Connected
7.	Not Connected
8.	Not Connected
9.	Not Connected

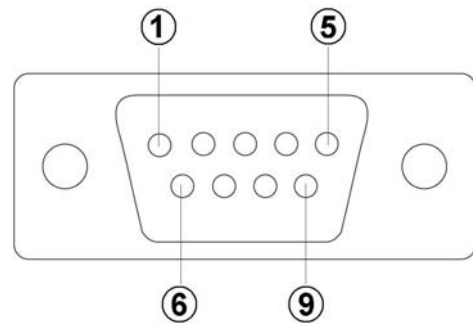

Set the **RS-232** option to **ON** in the **COMMUNICATION** page of the setup menu.

The transmission protocol is 8 data bit: 1 start bit, 1 stop bit and no parity. 8 different speeds can be used: 2400 baud per second, 4800 baud, 9600 baud, 19200 baud, 28800 baud, 38400 baud, 57600 baud and 115200 baud. The default setting is 9600 baud per second.

### 5.1.2 The Communication Protocol

#### 5.1.2.0 General Command Format

<Lead Code = 0x41>, < Dest ID >, < Src ID >, <Main category >, <Second category >, {<Number of parameters>, <Parameter 1>, <Parameter 2> ...} <End Code= 0x4f>

Lead Code = 0x41  
 Dest ID = 0x01  
 Src ID = 0x20  
 Main Category = 0x01 Keys and Signals  
                   = 0x02 Command  
 Second Category = 0x01 Handshake  
                   = 0x02 Request Time/Set Time  
                   = 0x06 Request System State  
                   = 0x0b Time Search  
                   = 0x10 Request HDD Info  
                   = 0x11 Request REC Position  
                   = 0x12 Playback Immediately  
 End Code= 0x4f

**The different command types and their corresponding parameters are as follows:**

# MISCELLANEOUS ( continued )

## 5.1.2.1 Keys and signals ( Main Category = 0x01 )

PC Send: <0x41>, <0x01>, <0x20>, <0x01>, <Key Value>, <0x4f>

### < The value of a specific front panel key >

	DEC	HEX
KEY_PLAY	1	0x01
KEY_STOP	3	0x 03
KEY_PAUSE	4	0x 04
KEY_REC	6	0x 06
KEY_SETUP	7	0x 07
KEY_ENTER	8	0x 08
KEY_SEARCH	10	0x 0A
KEY_DISPLAY	11	0x 0B
KEY_UP	13	0x 0D
KEY_DOWN	14	0x 0E
KEY_LEFT	15	0x 0F
KEY_RIGHT	16	0x 10
KEY_SCAN_F	19	0x 13
KEY_SCAN_R	20	0x 14
SIGNAL_REC_IN	163	0x A3
SIGNAL_ALARM_RESET	165	0x A5
SIGNAL_REC_OUT	169	0x A9
SIGNAL_ALARM_IN	189	0x BD
SIGNAL_ALM1_IN	193	0x C1
SIGNAL_ALM2_IN	194	0x C2
SIGNAL_ALM3_IN	195	0x C3
SIGNAL_ALM4_IN	196	0x C4
SIGNAL_ALARM_OUT	209	0x D1
SIGNAL_ALM2_OUT	210	0x D2
SIGNAL_ALM3_OUT	211	0x D3
SIGNAL_ALM4_OUT	212	0x D4
SIGNAL_HELP	239	0x EF

## 5.1.2.2 COMMAND (Main Category=0x02)

### A. Handshake (Second Category=0x01)

PC Request: <0x41>, <0x01>, <0x20>, <0x02>, <0x01>, <0x00>, <0x4f>

MDR-304 Response: <0x41>, <0x20>, <0x01>, <0x02>, <0x08>, <0x00>, <0x4f>

### B. Request Time (Second Category=0x02)

PC Request: <0x41>, <0x01>, <0x20>, <0x02>, <0x02>, <0x00>, <0x4f>

MDR-304 Response: <0x41>, <0x20>, <0x01>, <0x02>, <0x02>, <0x07>, <7 Time Value >, <0x4f>

The following case is an illustration of < 7 Time Value>

2004/06/20 17:05:00 = <0xD4>, <0x07>, <0x06>, <0x14>, <0x11>, <0x05>, <0x00>

### C. Set Time (Second Category=0x02)

PC Request: <0x41>, <0x01>, <0x20>, <0x02>, <0x02>, <0x07>, < 7 Time Value >, <0x4f>

The following case is an illustration of < 7 Time Value>

2004/06/20 17:05:00 = <0xD4>, <0x07>, <0x06>, <0x14>, <0x11>, <0x05>, <0x00>

MDR-304 Act: Changing the time and date.

#### D. Request State (Second Category=0x06)

PC Request: <0x41>, <0x01>, <0x20>, <0x02>, <0x06>, <0x00>, <0x4f>

MDR-304 Response: <0x41>, <0x20>, <0x01>, <0x02>, <0x06>, <0x01>, <System State = 0..>, <0x4f>

##### Description of <System State>:

STATE_STOP	0
STATE_PLAY	3
STATE_SETUP	6
STATE_SEARCH	7
STATE_BACKUP	15

#### E. Time Search (Second Category=0x0b)

PC send: <0x41>, <0x01>, <0x20>, <0x02>, <0x0b>, <0x06>, <6 Bytes Date/Time>, <0x4f> where < 6 bytes Date/Time >, = year (2 bytes, =LowByte + HighByte\*256), month (1 byte), day (1 byte), hour (1 byte), min (1 byte)

Example: to search 06/12/2004 17:00 the Date/Time = <0xd4>, <0x07>, <0x06>, <0x0c>, <0x11>, <0x00> where 2004= 212(=0xd4) + 7(=0x07) \*256

#### F. Request HDD Info (Second Category=0x10)

PC send: <0x41>, <0x01>, <0x20>, <0x02>, <0x10>, <0x00>, <0x4f>

MDR-304 Response: <0x41>, <0x20>, <0x01>, <0x02>, <0x10>, <0x32>, <0x00>, <0x00>, <48 Bytes Data> <0x4f>

<48 Bytes Data>=4 HDD Status( Primary Master/Slave, Secondary Master/Slave )

Every HDD use 12 Bytes=

- #0 :HDD Exist ( if = 1 )
- #1 :Active HDD ( if = 1 )
- #2 :Current HDD for REC ( if = 1 )
- #3 :Current HDD for PLAY ( if = 1 )
- #4...#7 :Capacity
- #8.. #11 :REC/PLAY Position

#### G. Request REC Position (Second Category=0x11)

PC send: <0x41>, <0x01>, <0x20>, <0x02>, <0x11>, <0x00>, <0x4f>

##### REC Mode

MDR-304 Response: <0x41>, <0x20>, <0x01>, <0x02>, <0x11>, <0x08>, <HDD#>, <0x0>, <4 Bytes REC Position>, <2 Bytes Image NO.>, <0x4f>

Get HDD#, REC Position and Image NO. used in **Playback Immediately** command

##### Non REC Mode

MDR-304 Response ERROR: <0x41>, <0x20>, <0x01>, <0x02>, <0x11>, <0x01>, <0x45>, <0x4f>

#### H. Playback Immediately (Second Category=0x12)

PC send: <0x41>, <0x01>, <0x20>, <0x02>, <0x12>, <0x0a>, <HDD#>, <0x0>, <0x0>, <0x0>, <4 Bytes REC Position>, <2 Bytes Image NO.>, <0x4f>

##### On Success

MDR-304 Response: <0x41>, <0x20>, <0x01>, <0x02>, <0x12>, <0x00>, <0x4f>

##### On Error

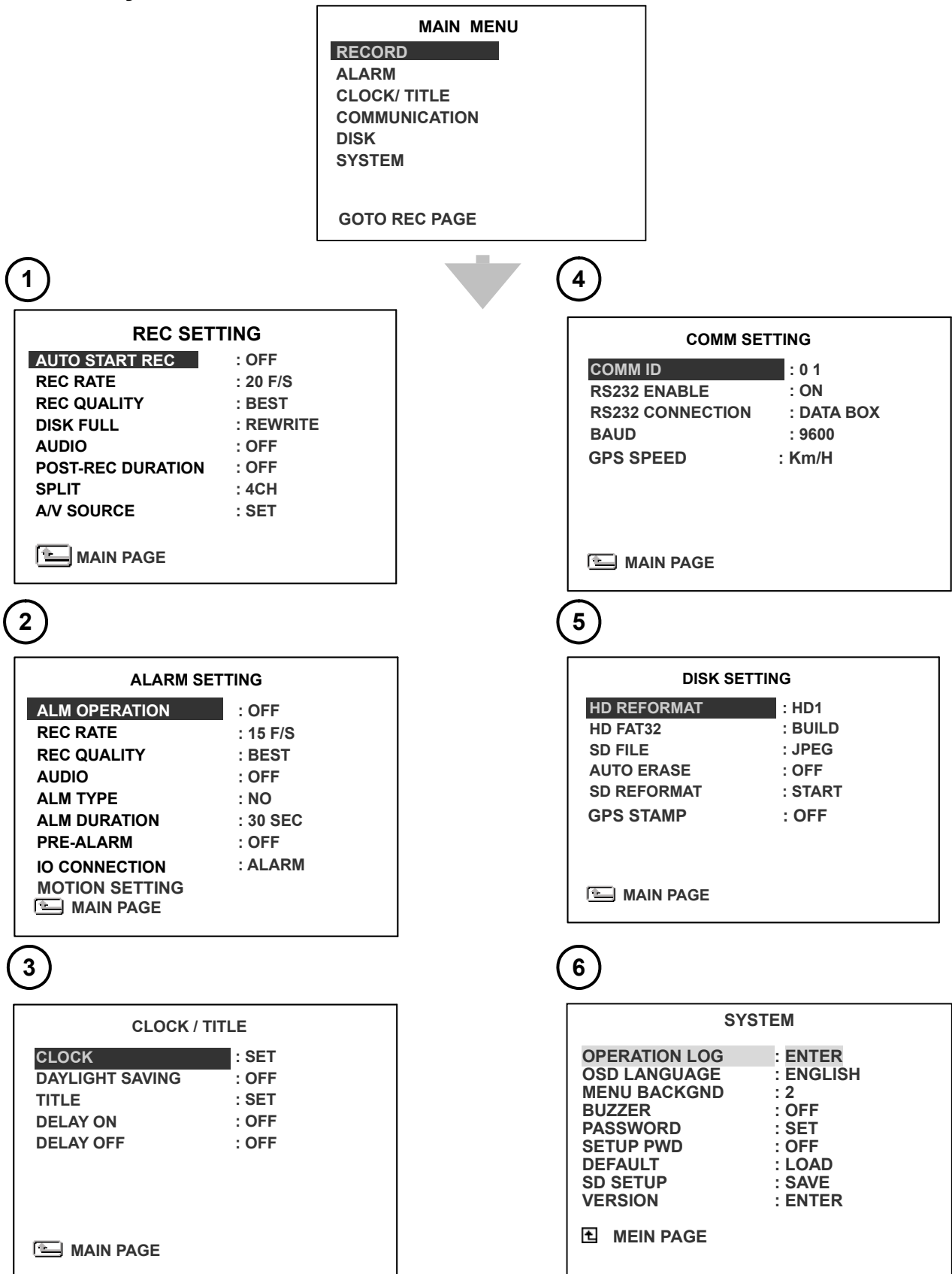

MDR-304 Response ERROR: <0x41>, <0x20>, <0x01>, <0x02>, <0x12>, <0x01>, <0x45>, <0x4f>

## 5.2 The System Default





## 5.3 O.S.D Messages

No.	O.S.D Message	Meanings
1	NO DISK	No hard disk detected after power activated
2	BATTERY LOW	Suggest change the battery
3	BATTERY HIGH	Suggest check the battery
4	LOADING	System Boot up
5	VIDEO LOSS	Video loss
6	VIDEO IN	Video input source
7	KEY LOCKED	Key lock function is on
8	KEY UNLOCKED	Key lock function is off
9	n1 OF n2 ITEMS PROGRESS n3 %	BACKUP n1/n2 NOW
10	BACKUP COMPLETE	Backup complete
11	NO ENTRY FOR BACKUP	No backup is possible.
12	BACKUP INCOMPLETE	Backup incomplete, since the user has pressed the STOP button to stop it
13	NOT FOUND	The system cannot find a video in the Search function.
14	END	Playback of recorded video has reached the end point
15	DISK FULL	Hard disks are full; this happens only when the DISK FULL item in the setup menu is set to STOP.
16	EMPTY	The user presses the PLAY button or uses the Search function, but no video can be played.
17	SET TO NTSC, PLS RESTART	System has to be set to NTSC, please reboot (PAL is similar)
18	SOFTWARE UPDATE	Software update
19	PLEASE RESTART	The system should be rebooted after the software has been updated
20	NO DISK	There is no disk.
21	SD CARD ERROR	The user has pressed the Save key without putting in an SD card.
22	FAN STOPPED	The chassis fan has stopped for over 30 seconds.
23	HDn ERROR AT xxxxx	There is a hard-disk error during recording, where n is the hard-disk number and xxxxx is the hexadecimal location.
24	NOT PRESENT	When the user tries to clear a disk that was not attached in the setup menu.
25	SAVE MXXXX.AVI TO SD CARD	Start saving to the AVI file.
26	SAVE TO Fnnnn. JPG	Start saving to the JPEG file (where nnnn= 0...9999)
27	SAVE OK	Saving to the JPEG or AVI is ok.
28	SD CARD WRITE PROTECT	An SD card is write-protected; or there is an error.
29	ACC OFF	Power off.
30		Received the leftside trigger signals.
31		Received the rightside trigger signals.
32		Received the brake triggering signal.

## 5.4 The Time Index Table

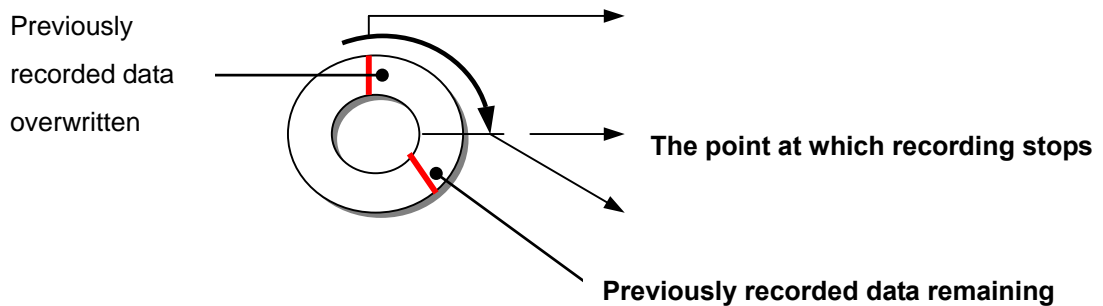
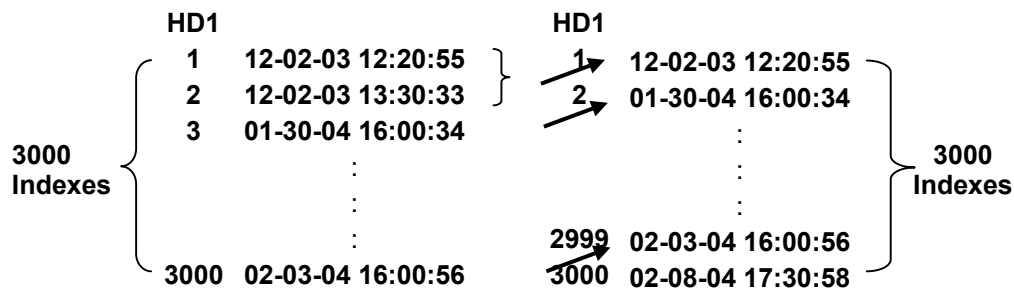

The MDR-304 will generate a **Time Index Table** indicating recorded data is kept in a particular HDD. This allows individually selected recorded data to be displayed via the alarm list search and full list search. The maximum number in a list for a given HDD is **3000**. When the list of any given HDD is used up and the disk is not full, the unit will still use the rest of the space for recording. In such a case, an index for the recent recorded data will be generated and the index of the next oldest data will be erased so that the list remains 3000 in total. And the next oldest data will be kept in the index of the

corresponding oldest data. For any newly-recorded data, this approach will be applied until the disk becomes full.

In the rewrite recording mode, when the archived hard disk drive is full, the MDR-304 will start overwriting the oldest data recorded. As the previous recorded data was partially overwritten by the recent recording, the indicating time index of that data will be changed corresponding to the starting time of the remaining session. The index of the session will be deleted from the table when it is fully overwritten.

## 5.5 Specifications

<b>Model</b>	<b>MDR-304</b>	
<b>Image System</b>	NTSC	PAL
<b>Resolution</b>	720x480 pixels	720x576 pixels
<b>Video In</b>	(DIN) x 4 ---(With 12VCC & GND)	
<b>Video Out</b>	Monitor Out (RCA x 1)	
<b>Audio in/out</b>	Line in (RCA x 2) / out (RCA x 1), 11kHz/22kHz	
<b>Operation Mode</b>	Play, Record or Standby	
<b>Compression</b>	MJPEG	
<b>Storage Media</b>	Upto 250GB Micro-Driver	
<b>Memory Card</b>	SD Card	
<b>Watermark</b>	Digital Signature	
<b>Window Division</b>	1 / 2 / 3 / 4	
<b>Recording Rate(Frame)</b>	30 FPS/CH	25 FPS/CH
<b>Display Rate</b>	30 FPS/CH	25 FPS/CH
<b>Picture Quality</b>	Best(64KB)/High(32KB)/Standard(21KB)/Basic(16KB)	
<b>Recording Mode</b>	Manual / Alarm	
<b>Recording List</b>	3000 Records	
<b>Alarm Record</b>	Pre-alarm / Post alarm	
<b>Pre-alarm Record</b>	50 images	
<b>Playback Speeds</b>	Frame Stepping, 1X, 2X, 4X, 8X, 16X, 30X, 100X, 1/2X, 1/4X, 1/8X, 1/16X	
<b>Record Search</b>	Time & Date/ Full list/ Alarm list/ Filter (thumbnail)	
<b>Set-up Menu</b>	Multi-layer	
<b>Log List</b>	2000 Records	
<b>GPIO</b>	Input x 4; Output x 2	
<b>Wired Remote Controller</b>	Yes (Length: 3M)	
<b>Vibration</b>	1.25G (Random) / 0.8G (Sine)	
<b>Mechanical Shock</b>	8G	
<b>Built-in buzzer</b>	Yes	
<b>Communication Port</b>	RS-232	
<b>USB</b>	B-Type, Slave mode	
<b>GPS Supported</b>	Yes	
<b>Software Upgrade</b>	Upgrades via Memory Card (SD)	
<b>Password Protection</b>	Operation /Menu Setup	
<b>Operation Power</b>	11~14.5Vdc	
<b>Power Consumption</b>	15W	
<b>Delay-off</b>	Yes (Max. 30A)	
<b>Dimensions</b>	178 x 173 x 50 mm	
<b>Operation Temperature</b>	Standard HDD: 0 – 45°C (32 –113°F)	
<b>Certificate</b>	FCC, CE, E/e-mark, RoHS	

**Note:** The maximum electric voltage provided for 4 mobile cameras is 1 ampere (1A) in total.

**Note:** Design and specifications are subject to change without notice.

## **APPENDIX 1. –FAQ**

### **1. How do I choose a channel in the play mode?**

ANS: If you want to choose a channel in the play mode, press the **SEARCH** button to enter the "SEARCH" menu. Next choose "FULL LIST" and push the **Enter** button to enter the record list page. Use the **Up** and **Down** buttons to select the record you want. Then press the **Enter** button again to enter the quad mode screen. Now press the channel buttons to let your desired channels be displayed on the full screen.

**Note:** The channel - access buttons are the Up and Down, and Left and Right, buttons.

**Note:** If you want to leave the play mode, click the "Stop" button to exit the play mode for the live mode.

### **2. How do I use the audio functions in the play mode in the camera channels?**

ANS: When you press the "PLAY" button to enter the play mode, you then press the **SEARCH** button to change the two audio sources to any one or two of the four cameras you have. The audio types are of three kinds: Audio 1, Audio 2, and Audio 1 + 2, accessible in this order with each successive sequential click. You can set up Audio 1 and Audio 2 in separate channels. Press the **SEARCH** button once to hear the audio in any one channel. Press "SEARCH" again to hear the audio in another channel, the two audios playing together. If you press the **SEARCH** button again, you can play Audio 1 and Audio 2 together in any one single channel. The sound is better if you play both Audio 1 and Audio 2 in one channel.

## **APPENDIX 2: Quick Installation Guide**

### A. Installation methods

#### **⚠ Warning**

- ⦿ Do not take apart and reassemble the MDR-304, as this may possibly cause a fire, electronic shock, or even a vehicle accident.
- ⦿ Please contact with your retail store or customer service center for any repairs.
- ⦿ Please do not introduce any alien parts or material into the MDR-304.
- ⦿ Do not drop or damage the MDR-304.

#### **※ Steps:**

1. Screw the MDR-304 into its shockproof rack tightly.
2. Screw in the shockproof rack onto a flat surface where you want to fix it.

PS: If you want to settle the MDR-304 inside the trunk, fix it to the roof of the trunk (see the MDR-304 in this position in picture2).

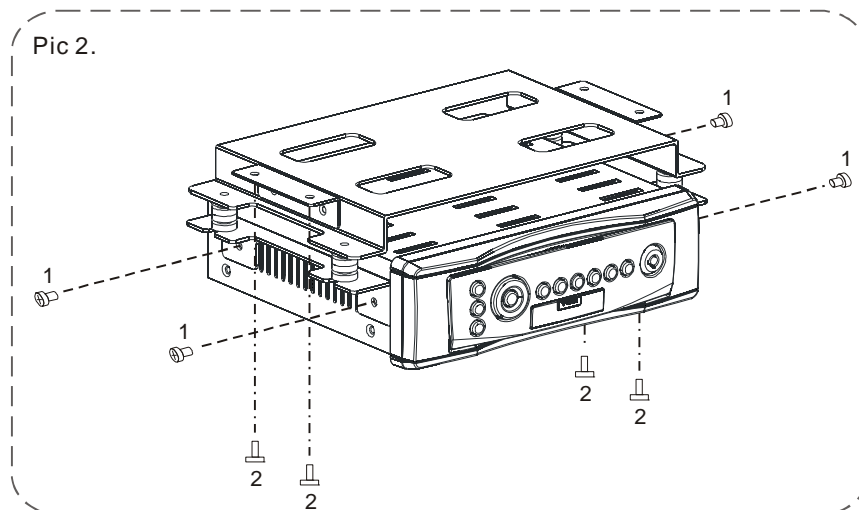
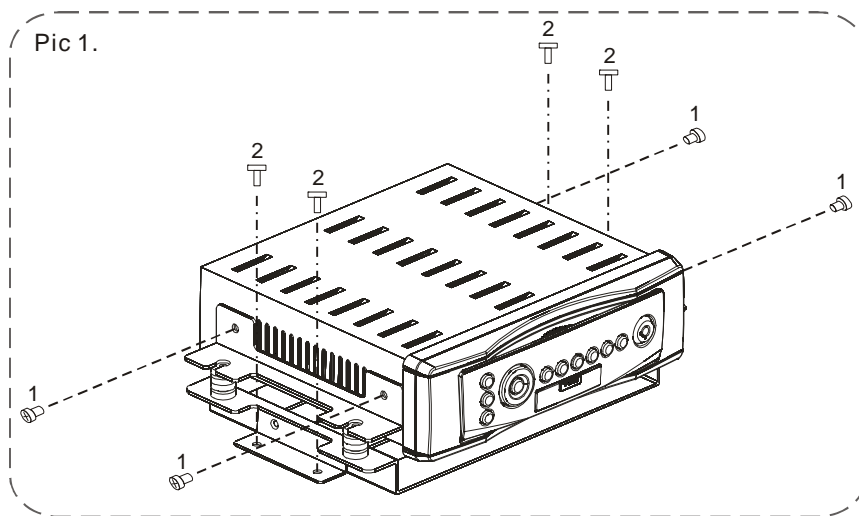

## B. Installation environment

### ⚠ Warning

- ⊙ Install the MDR-304 on a flat surface inside your car and lock it tightly.
- ⊙ Please make sure of the locations of the pipeline, fuel tank, and electronic wire in your car before making a hole for the MDR-304 inside the car.
- ⊙ Please avoid destroying the pipes, fuel tank, or electronic wire, as this possibly causes a fire.
- ⊙ Please don't install the MDR-304 and its connection lines in positions and places that obstruct normal driving behavior and cause an accident, electronic shock, or fire.
- ⊙ Assembly of the connection lines and power lines
  - (a) Please cleanse your car of dust, grease, and wax-like substances, before you attach the lines.
  - (b) Please wrap the connection lines securely so they don't interfere with your driving movements.
- ⊙ Please don't loop any power lines around the thread hole, sliding rail or release dial of the device.
- ⊙ Please check that the operation of the steering wheel, gearshift lever, and brake pedal are working properly after the installation.

※ Suggestions for installation:

1. The top of the trunk.
2. The bottom of the trunk.

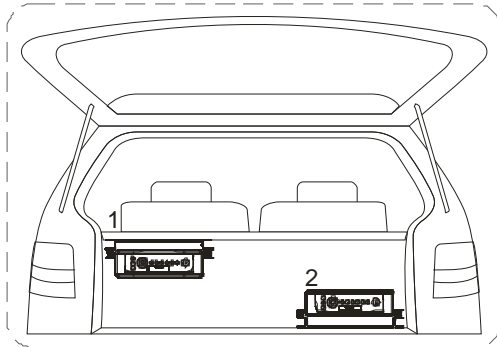

3. The bottom of the bucket seat.

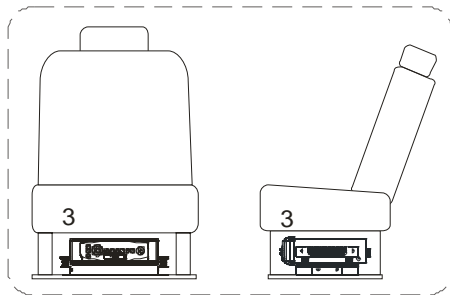

## C. Installation of the connection lines

### ⚠ Warning

- ⊙ Please have the MDR-304 installed by the retailer from whom you purchased it.
- ⊙ Professional technical knowledge is needed for the installation.
- ⊙ Please install the MDR-304 by following the installation guide operation manual step by step if you do it yourself. If you don't, erroneous installation will cause the possibility of fire or electronic shock.
- ⊙ Please stop the vehicle's operation and take your key off before the installation. If you don't, there is the possibility of a short circuit, fuse and explosion of the interior lights, or smoke emission.
- ※ Connecting the cables:  
Please follow the steps from one to nine.

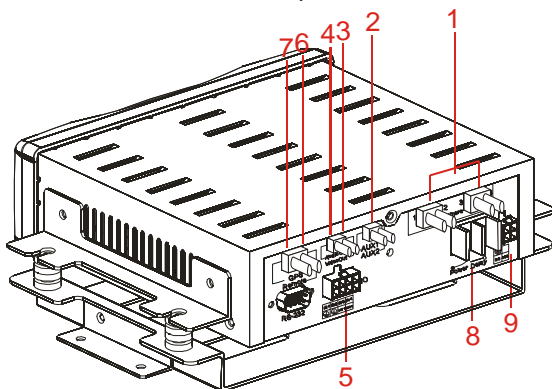

### 1. Camera connection

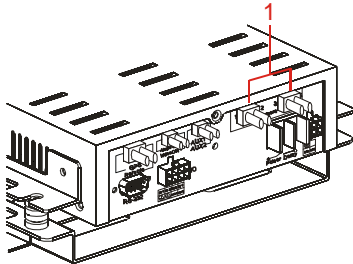

⊙ Please connect the video camera with its cable.

- a. Connect the camera MD 50 (optional).
- b. Connect the other brands' cameras with the connection cable of the MDR-304. The connection cable is separated into two plugs. One is for image transmission, and the other one is for power transmission.

### 2. Audio input connection

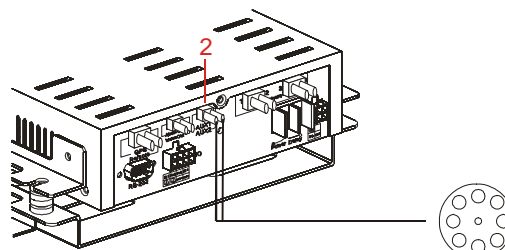

⊙ Please connect an external audio receiver (for example, a microphone) with the audio input cable.

### 3. Video output connection

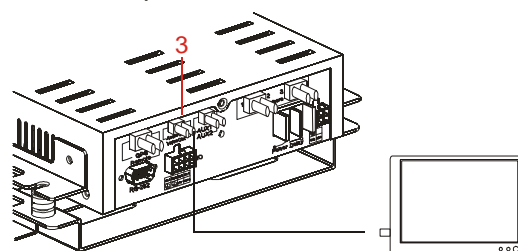

⊙ Please connect a video player (for example, a vehicle monitor) with the video output cable.

### 4. Audio output connection

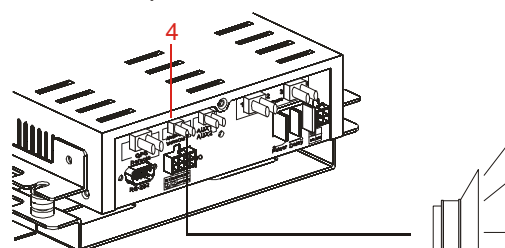

⊙ Please connect the audio player (for example, a vehicle speaker) with the audio output cable.

### 5. I/O Socket

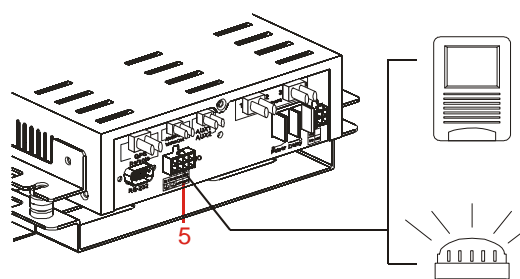

⊙ Please connect the I/O socket with other internal functions (for example, lock / turning signal / brake light, or alarm).  
For the detailed setting, please check the operation manual, pages 13 and 14.

## 6. Controller connection

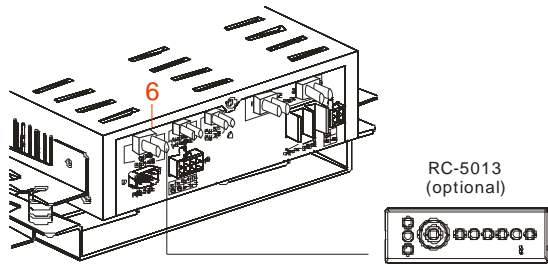

Ⓞ Please connect the controller (RC-5013: optional) with the controller's cable.

## 7. GPS connection

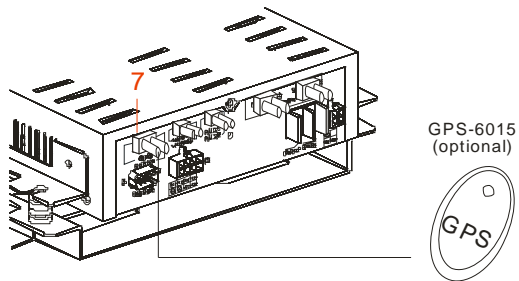

Ⓞ Please connect the GPS (GPS-6051: optional) with the GPS' cable.

## 8. Power delay socket

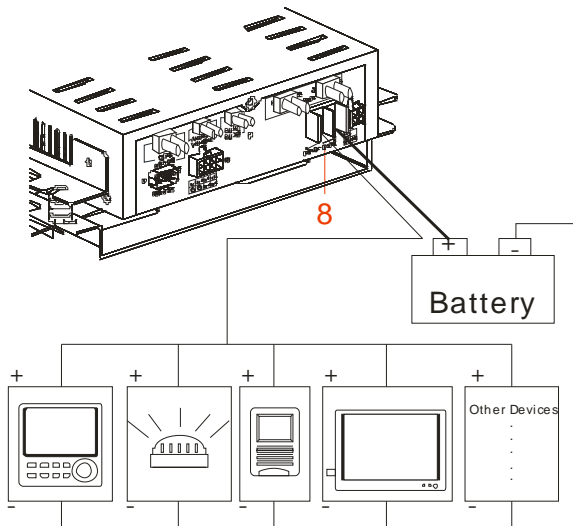

Ⓞ Please connect the cables of other vehicle products, like the monitor, alarm light, or vehicle video player, for power delay management.

### Description:

If there are too many electronic vehicle products connected at the same time, it could cause a power supply shortage and make the vehicle power system work poorly. Hence power delay management may be needed.

For the detailed setting, please check the operation manual, page34.

## 9. Power socket

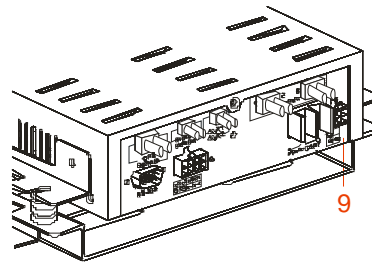

### ACC for power supply

As in the picture below, please connect the positive of the cigar-lighter with the power input (DC), and then connect the black light with the negative of vehicle battery.

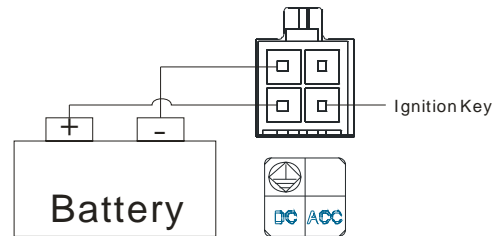

P.S.: This connection method is suitable for users who have special requirements. It can also operate when the engine is turned off. For the detailed setting, please check the operation manual, page30.







Brigade Electronics plc

Brigade House, The Mills, Station Road, South Darent, Kent DA4 9BD

Sales +44(0) 1322 420300 Facsimile +44(0) 1322 420343

[www.brigade-electronics.com](http://www.brigade-electronics.com) [sales@brigade-electronics.com](mailto:sales@brigade-electronics.com)

